

SCIENCE OF GYMNASTICS JOURNAL

vol. 9, num. 1, year 2017



Science of Gymnastics Journal (ScGYM®)

Science of Gymnastics Journal (ScGYM®) (abbreviated for citation is SCI GYMNASTICS J) is an international journal that provide a wide range of scientific information specific to gymnastics. The journal is publishing both empirical and theoretical contributions related to gymnastics from the natural, social and human sciences. It is aimed at enhancing gymnastics knowledge (theoretical and practical) based on research and scientific methodology. We welcome articles concerned with performance analysis, judges' analysis, biomechanical analysis of gymnastics elements, medical analysis in gymnastics, pedagogical analysis related to gymnastics, biographies of important gymnastics personalities and other historical analysis, social aspects of gymnastics, motor learning and motor control in gymnastics, methodology of learning gymnastics elements, etc. Manuscripts based on quality research and comprehensive research reviews will also be considered for publication. The journal welcomes papers from all types of research paradigms.

Editor-in-Chief Ivan Čuk, Slovenia
Responsible Editor Maja Bučar Pajek, Slovenia

Editorial and Scientific Board

Koichi Endo, Japan
Marco Antonio Bortoleto, Brazil
Nikolaj Georgievic Suchilin, Russia
William Sands, USA
Kamenka Živčič Marković, Croatia
Ignacio Grande Rodríguez, Spain
Warwick Forbes, Australia
David McMinn, Scotland, UK
Almir Atiković, Bosnia and Herzegovina
José Ferreirinha, Portugal
Istvan Karacsony, Hungary
Hardy Fink, FIG Academy, Canada
Keith Russell, FIG Scientific Commission, Canada

Science of Gymnastics Journal is indexed in

Web of Science (ESCI data base, since 2015), EBSCOhost SPORTDiscus, SCOPUS, COBISS (IZUM), SIRC (Canada), ERIHPLUS, OPEN. J-GATE, GET CITED, ELECTRONIC JOURNALS INDEX, SCIRUS, NEW JOUR, GOOGLE SCHOLAR, PRO QUEST and INDEX COPERNICUS. ScGYM® (ISSN 1855-7171) is an international online journal published three times a year (February, June, October). ® Department of Gymnastics, Faculty of Sport, University of Ljubljana. All rights reserved. This journal and the individual contributions contained in it are protected under Copyright and Related Rights Act of the Republic of Slovenia.

Front page design: Sandi Radovan, Slovenia.

Editorial Office Address

Science of Gymnastics Journal
Faculty of Sport, Department of Gymnastics
Gortanova 22, SI-1000 Ljubljana, Slovenia
Telephone: +386 (0)1 520 7765
Fax: +386 (0)1 520 7750
E-mail: scgym@fsp.uni-lj.si
Home page: <http://www.scienceofgymnastics.com>

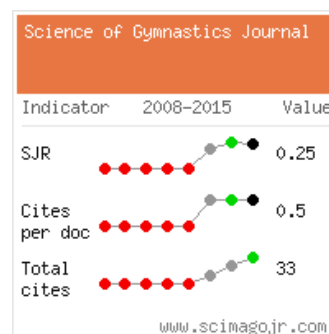

Science of Gymnastics Journal is supported by Foundation for financing sport organisations in Slovenia, Slovenian Research Agency and International Gymnastics Federation.



CONTENTS

Ivan Čuk	EDITORIAL	3
A. Kochanowicz K. Kochanowicz B. Niespodzinski J. Mieszkowski P. Sawicki	EFFECTS OF SYSTEMATIC GYMNASTICS TRAINING ON POSTURAL CONTROL IN YOUNG AND ADULT MEN	5
N. Karachle A. Dania F. Venetsanou	EFFECTS OF A RECREATIONAL GYMNASTICS PROGRAM ON THE MOTOR PROFICIENCY OF YOUNG CHILDREN	17
G.C. Dallas C.G. Dallas E.J. Simatos J.E. Simatos	NUTRITIONAL RECOMMENDATIONS AND GUIDELINES FOR WOMEN IN GYMNASTICS: CURRENT ASPECTS AND CRITICAL INTERVENTIONS	27
J. Zurec	IT WAS WORT – I WOULD DO IT AGAIN!: PHENOMENOLOGICAL PERSPECTIVES ON LIFE IN THE ELITE WOMENS ARTISTIC GYMNASTICS	41
I. Pušnik I. Čuk V. Hadžič	INFLUENCE OF NEW ANATOMIC RING DESIGN ON PALM SKIN TEMPERATURE	61
G.C. Dallas P. Kirialanis C.G. Dallas V. Mellos	THE EFFECT OF TRAINING IN MAXIMAL ISOMETRIC STRENGTH IN YOUNG ARTISTIC GYMNASTS	71
E. Kolar S. Piletič K. Bedenik M. Samardžija Pavletič S. Štuhec S. Veličković	KINEMATIC ANALYSIS OF THE NEW ELEMENT “DIMIC” AND ITS COMPARISON WITH “BILOZERCHEV” ON PARALLEL BARS	83
Anton Gajdoš	HISTORICAL SHORT NOTES VIII	97
	SLOVENSKI IZVLEČKI / SLOVENE ABSTRACTS	100
	REVIEWERS IN 2016	104
	NEW BOOKS	105

EDITORIAL

Dear friends,

I hope you started 2017 healthy, happy and with a lot of new gymnastics-related plans. For us, our work on the Journal continues. Last year we published 20 articles and for this year we plan to do the same. We are proud that our articles are referred to by others journals. For even more streamlined appearance we will prepare a template with formatting instructions for your future articles and make it available on our website.

The first article in this issue comes from a group of researchers from Poland lead by Andrzej Kochanowicz. They looked at how gymnastics experience affects body posture and found that gymnastics does have an impact on better equilibrium in standing position. Those of you who work in kindergartens and schools might find this important.

The second article deals with the effects of gymnastics programs on motor proficiency in young children. Greek authors Nafsika Karachle, Aspasia Dania, Fotini Venetsanou found that recreational gymnastics did have a significant influence on motor proficiency on their sample group.

The third article also comes from Greece. A research group lead by George C. Dallas touched on another key issue – proper diet and the importance of minerals and vitamins in particular. Our sport requires a specific shape and a highly efficient body which may conflict with the predominant cultural attitudes. The authors of this article consider how this gap could be bridged.

The fourth article is by Joca Zurc from Slovenia and brings an analysis of interviews with 37 females who were or still are active in artistic gymnastics. All participants found their involvement in gymnastics as something positive and would do it again.

The fifth article is from a Slovenian group lead by Igor Pušnik. The group has created a new and more ergonomic design of rings and compared their design with classic rings. It was an unusual experience and produced unusual results.

The sixth article is from the same Greek group of researchers lead by George Dallas as our third article. In this one the group explored the effects of training maximal isometric strength in young artistic gymnasts.

The last article comes from Slovenia. A group led by Edvard Kolar analysed new element Dimic on parallel bars and compared the results with the Bilozerchev element.

Anton Gajdoš prepared a new contribution on gymnastics history. Our first issue brings a list of all reviewers who participated in our Journal in 2016 with our thanks for their individual contributions. And there is also an announcement for a new book by Kamenka Živčič Marković and Tomislav Krstičević.

Just to remind you, if you quote the Journal: its abbreviation on the Web of Knowledge is SCI GYMN J. I wish you pleasant reading and a lot of inspiration for new research projects and articles,

Ivan Čuk
Editor-in-Chief

EFFECTS OF SYSTEMATIC GYMNASTIC TRAINING ON POSTURAL CONTROL IN YOUNG AND ADULT MEN

Andrzej Kochanowicz¹, Kazimierz Kochanowicz², Bartłomiej Niespodziński³,
Jan Mieszkowski³, Piotr Sawicki¹

¹Department of Gymnastics and Dance, Gdansk University of Physical Education and Sport, Gdańsk, Poland.

²Department of Theory of Sport and Human Motorics, Gdansk University of Physical Education and Sport, Gdańsk, Poland.

³Institute of Physical Education, Kazimierz Wielki University, Bydgoszcz, Poland.

Original article

Abstract

The aim of the study was to investigate the influence of gymnastics expertise of children and adolescents and young adults on the postural control with and without the use of visual information and during dynamic postural task. The study comprised a total of 105 males, including 48 athletes practicing gymnastics and 57 non-gymnasts. Both groups were divided into three age categories: 8-10, 12-14 and 18-24 years old. Participants' postural control was measured on force platform in bipedal static (eyes open/close) and dynamic with visual feedback condition. ANOVA test (group vs age) with repeated measurements (visual control) was used to distinguish effect of gymnastic training in three age groups. Results show that in analysis of the center of pressure surface area, all gymnast had significantly better ($p=0.013$) static postural control in regardless visual control (group effect), although, there were no differences in each individual age groups (group vs age; $p=0.556$). Furthermore, the youngest groups had significantly higher values than two other groups, indicating worse performance. Dynamic task with visual feedback showed that the youngest non-gymnasts needed much more time to complete the task in compare to all other groups of gymnasts or non-gymnasts. The results showed that gymnastic training has influence in postural control of young and adults, but unspecific static and visual feedback condition does not fully reflect adult gymnast's capabilities. However, systematic participation in gymnastics training during the early-school period could increase the ability to coordinate and regulate body posture.

Keywords: *balance, visual feedback, sensory reintegration, proprioception, training adaptation.*

INTRODUCTION

Maintaining upright body posture is extremely difficult from a biomechanical point of view due to the small surface of support and a complicated system of kinetic chains with multiple degrees of freedom (Bairstow & Laszlo, 1981; Dallas, Dallas, Theodo, & Papouliakos, 2016; Tsopani et al., 2014). When performing daily activities

such as locomotion (walking on flat, uneven surfaces, stairs etc.), physical labour in a standing position and many other, a person uses them to a small extent. By far a greater wealth of activities related to maintaining body balance is observed in sport. Efficient postural control results from complex physiological mechanisms, including,

among others, the functions of the organ of sight (Cody & Nelson, 1978), proprioception (Fujisawa et al., 2005), the central and the peripheral nervous system (Kavounoudias, Gilhodes, Roll, & Roll, 1999), the vestibular organ (Iatridou, Mandalidis, Chronopoulos, Vagenas, & Athanasopoulos, 2014). Through sensory organization, a person efficiently maintains body balance while walking or running and performs many complex movements (Andersson, Hagman, Talianzadeh, Svedberg, & Larsen, 2002; Winter, 1995).

Carrick, Oggero, Pagnacco, Brock, and Arikian (2007), Freeman and Broderick (1996), Taniewski, Zaporozhanow, Kochanowicz, and Kruczkowski (2001) emphasize that the development of the postural control is influenced by practical activity and gaining different experiences since the earliest years. At the age of 3–4 an assessment of the overall position of the body and its individual parts is already partly stabilised. At the age of 5–6 a child develops an ability to evaluate the correct body posture, develops a habit of dynamic balance, expands the range of differentiation of particular body positions and conditions for taking them. In some 9-year-old gymnasts coordination skills in maintaining upright body posture, in terms of a unspecific static posturographic assessment, are not significantly different from adults (Kochanowicz, 2010).

Artistic gymnastics is one of the sports, where most gymnasts start their trainings at an early age of 6-7 years (Garcia, Barela, Viana, & Barela, 2011; Kochanowicz, Boraczyńska, & Boraczyński, 2009), thus their natural postural control development is influenced by gymnastic training. Gymnasts have to operate their bodies in space and on various apparatuses, (balance beam, pommel horse, still rings, dismounts, floor acrobatics etc.) where body changes rapidly the position of centre of gravity. Therefore, through intensive training they are able to perform many exercise that require a great sense of balance (Croix, Chollet, & Thouwarecq, 2010).

Many studies have been conducted to investigate the influence of gymnastic expertise on the postural control in various conditions. Garcia et al. (2011) observed that 5–7-years-old gymnasts had better postural control in static conditions with visual information in comparison to control peers, but older 9–11-year-old gymnasts and non-gymnasts did not differ in their performance with eyes opened or closed. Although, Mellos et al (2014) showed better performance of 9-10-years old gymnasts in comparison to untrained controls in flamingo balance test. F. B. Asseman, Caron, and Cremieux (2008) showed that adult gymnasts in comparison with other non-gymnast athletes demonstrated better performance only in a unipedal posture regardless of visual condition. In contrast, Vuillerme, Danion, et al. (2001) observed no difference between adult gymnasts and other athletes in postural control during a bipedal or unipedal posture. Although they noticed the influence of vision on the performance, where gymnasts demonstrated better results, especially in more difficult postures (unipedal and unipedal on the foam surface). Moreover, Asseman, Caron, and Cremieux (2004) in another study showed that there was no transfer of postural ability from the handstand or a unipedal posture to an unspecific bipedal posture. The mentioned studies suggest that postural control in static conditions might not be altered by gymnastic expertise after its establishing at the age of 8-9 and other more specific tests should be performed for gymnasts.

On the other hand, gymnasts' abilities of adjusting to various postural perturbations presents different results. Gymnasts demonstrated better performance in reweighting proprioceptive information (Vuillerme, Teasdale, & Nougier, 2001), lower attentional demand for regulating postural sway (Teasdale & Simoneau, 2001) and a shorter sensory-motor delay (Gautier, Thouwarecq, & Larue, 2008) as well as specific modifications of postural regulation (Gautier, Thouwarecq, & Vuillerme, 2008; Marin, Bardy, & Bootsma, 1999). Some

studies (Dallas et al. 2016, Chen et al. 2016) used comprehensive methods of sensory organization test to evaluate the integrity of three systems (visual, vestibular, and somatosensory) in gymnasts. Chen et al. (2016) showed that 15-years old gymnasts had similar sensory organisation ability in comparison to untrained peers, although their performance was better when the visual information was unreliable. As appears from the above, that the most of the studies were performed on adult gymnasts and their untrained counterparts or other non-gymnast athletes. There is also lack of concurrence about the impact of gymnastic expertise on the visual component in postural control. Therefore, the aim of the study was to investigate the influence of gymnastics expertise of children, adolescents and young adults on the postural control with and without the use of visual information in particular their ability to visually control the center of pressure.

METHODS

The study involved a total of 105 male subjects, including 48 athletes practicing gymnastics (G) and 57 non-gymnasts (NG). Both groups were divided into three age categories. The first category consisted of children aged 8–10 years (G1, n = 21; NG1,

n = 21), the second one comprised 12-14-year-old boys (G2, n = 15; NG2, n = 20), and the third one included 18–25-year-old men (G3, n = 12; NG3, n = 16). All the studied gymnasts started their training at the age of 6–7 years. The youngest gymnasts' group trained for about 22 hours a week and the middle and the oldest group trained from 24 to 26 hours a week. They were distinguished by very high sports achievements at the national and the international level. The non-training group declared no participation in sport and they were matched with gymnasts considering body mass and height. The participants were characterized by appropriate health status during the previous three months (they had not taken any pharmacological substances). The level of the subjects' basic morphological characteristics is presented in Table 1. There were no significant differences between participants in particular age groups, considering the height and the body mass. However, difference between each age group could be observed. The study was conducted with an approval of the Bioethics Committee at the Regional Medical Chamber in Gdańsk with approval number of KG -12/15. All participants as well as children's legal guardians gave informed consent to this study.

Table 1

Mean values and standard deviations of morphological characteristic of gymnasts (G) and non-gymnasts (NG) aged 8-10 years, 12-14 years, 18-25 years

		Non-gymnasts	Gymnasts	p
Height (cm)	8 – 10 years	135.6 ± 6.1	132.1 ± 6.9	0.153
	12 – 14 years	158.3 ± 8.6	154.9 ± 9.8	0.314
	18 – 25 years	175.2 ± 6.1	172.5 ± 4.0	0.193
Body mass (kg)	8 – 10 years	32.4 ± 6.4	30.1 ± 3.8	0.177
	12 – 14 years	45.8 ± 8.6	42.6 ± 7.6	0.283
	18 – 25 years	75.5 ± 14.2	72.0 ± 5.1	0.414
BMI	8 – 10 years	17.9 ± 3.0	16.7 ± 1.2	0.121
	12 – 14 years	17.9 ± 1.8	18.6 ± 1.2	0.208
	18 – 25 years	24.9 ± 4.7	24.1 ± 0.9	0.560

The study of postural control was conducted in the morning in a quiet indoor laboratory on an AccuGait force platform recording the displacement of center of pressure (COP) using the AMTI software. Measurement of static postural control in the upright position on both legs with eyes open (EO) and closed (EC) took place for 30s with a frequency sampling of 100 Hz. During all measurements, participants' feet were placed parallel and at pelvis width. Children put their hands alongside the hips and they were instructed to stay still during all measurements.

After the static measurements, the dynamic postural control with visual feedback evaluation was performed. The subject's position was the same as in the static balance trial. The time of recording the visual feedback body balance test with the 100 Hz sampling rate depended on the efficiency of the performed trial. The shorter the trial realization time, the better the performance. The trial consisted in achieving targets displayed on a 20-inch monitor screen positioned at a distance of one meter in front of the participant and at his line of sight. Each target was positioned at the line of 85% base of support (BOS). Circle-shaped targets in size of 10% BOS appeared on the monitor screen in consecutively designated locations: T0 (central) T1 (front), T0 (central), T2 (right-side), T0 (central), T3 (back), T0 (central), T4 (left-side) and T0 (central) (see Fig 1.). The target was considered achieved if the projection of the subject's COP remained within the circle for 1 seconds. Targets were displayed in exact same order for each participant and when the subject's COP reached indicated target it was highlighted.

Once the target has been achieved, another one appeared. The total number of targets to be achieved in the trial was eight. In study analysis numeric values only from the central (mean of four T0 targets) were taken into consideration. Subjects started test always from the central position, after maintaining 5 seconds at starting target in size of 10% BOS. During this task participants were instructed to reach with a

cursor (visualization of their COP) the displayed target as soon and as precisely they could and to maintain at it until the next target appeared. Reliability of measuring device was previously investigated and included research involving both gymnasts (Croix et al., 2010; Harringe, Halvorsen, Renström, & Werner, 2008) and non-trained participants (Geldhof et al., 2006; Stemplewski, Maciaszek, Osiński, & Szeklicki, 2011) and demonstrated from good to excellent reliability.

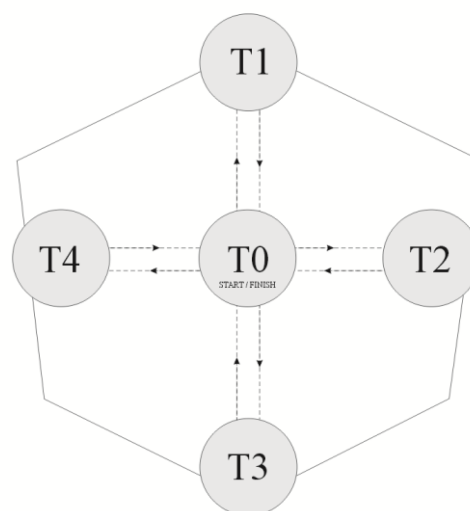

Figure 1. Designated locations: T0 (central) T1 (front), T0 (central), T2 (right-side), T0 (central), T3 (back), T0 (central), T4 (left-side) and T0 (central).

It should be stressed that a day before the study of postural control the subjects took a session acquainting them with the procedure, which consisted in three-time repetition of the trials after their clear explanation. All body balance trials were carried out three times with one-minute intervals. The best result, which in terms of postural control was the lowest value, was taken into consideration for further analysis. The level of static postural control in the upright standing position on both legs with open and closed eyes was defined by the COP surface area of the 95th percentile ellipse (surface area [mm²]). Moreover, to determine the level of dynamic postural control with visual feedback, the sum of times to achieve a target divided by the use

of the target (Avg Achievement Time Index [s]) was taken into consideration.

To specify the differences in the measured posturographic indices between the non-training and the gymnastic groups in each age category, in terms of both visual control and without it, three-way ANOVA (*group vs age*) with repeated measurements (*visual control*) was used. The *group* effect determined whether the individual was a gymnast or not, which represented an impact of gymnastic training, and the *age* effect considered belonging to one of the three age categories, which implies the role of somatic development. The impact of *visual control* on static postural control was defined by the repeated measurements factor in form of performance with eyes opened and eyes closed. In a study of differences in the ability to control the center of pressure in conditions of visual feedback, two-way ANOVA was used (*group vs age*). Statistically significant main effects and their interactions were subjected to the Post Hoc-Tukey test. In addition, effect size of each factor was calculated using the Eta-squared (η^2) statistics.

The statistical significance was considered at $p < 0.05$. Shapiro-Wilk and Levene tests were performed to check the normal distribution and homogeneity of variance, respectively.

RESULTS

All statistical results of the main effects as well as interaction between them in ANOVA test can be found in Table 2.

Analysis of the mean values of the surface area in the non-training group ($3.19 \pm 2.59 \text{ cm}^2$) and among gymnasts ($2.31 \pm 2.20 \text{ cm}^2$), showed significant effects of the *group* factor ($p < 0.05$). The *age* effect also turned out to be significant ($p < 0.001$). The obtained values show that with age there is a marked trend to narrow the field of COP sways in all subjects. However, it should be noted that the difference in the mean value of surface area was significant only between subjects aged 8–10 years ($4.36 \pm 2.75 \text{ cm}^2$) and two other groups: aged 12–14 years

($2.12 \pm 1.62 \text{ cm}^2$) and aged 18–24 years ($1.07 \pm 0.65 \text{ cm}^2$). The results of the static postural control among the oldest subjects were on the verge of significance in comparison to the younger age category. The interaction between *age* and *group* effect showed to be insignificant ($p > 0.05$) and the main effect of *visual control* was significant ($p < 0.0001$) in the form of lower surface area in EO ($2.02 \pm 1.73 \text{ cm}^2$) in comparison to EC ($3.47 \pm 3.14 \text{ cm}^2$) condition. An interaction between *visual control* and *age* was also significant ($p < 0.05$) where differences between performance in EO and EC were significant only in the age group of 8–10 (EO: $3.23 \pm 2.0 \text{ cm}^2$ vs EC: $5.50 \pm 3.54 \text{ cm}^2$) and 12–14 (EO: $0.80 \pm 0.41 \text{ cm}^2$ vs EC: $1.35 \pm 0.90 \text{ cm}^2$). An Interaction between *group* and *visual control* ($p > 0.05$) as well as the interaction between the *group*, *age* and *visual control* effect of static postural control defined by the surface area showed to be insignificant ($p > 0.05$). However, it needs to be stressed that in all age categories gymnasts achieved better results than non-gymnasts in postural control with both eyes open and eyes closed (see Fig. 2).

In the analysis of dynamic balance task with visual feedback, differences between groups were reported in the Avg Achievement Time Index. For this variable, the effect of the *group* factor turned out to be significant at $p < 0.05$, where results of non-gymnasts and gymnasts were 8.66 ± 8.14 and 5.73 ± 3.74 s, respectively. The analysis of the *age* effect also showed a significant result ($p < 0.001$), where the significant differences were observed between the 8–10-year-olds (10.49 ± 7.91 s) and 12–14-year-olds (5.36 ± 4.56 s) and 18–25-year-olds (5.16 ± 4.88 s). Interaction between the *group* and the *age* factors (see Fig. 3) showed to be significant ($p < 0.05$). It should be emphasised that the differences in gymnasts and non-gymnasts in each age category was significant only in reference to the youngest non-training boys.

Table 2

Analysis of the static and dynamic postural control with visual feedback. Two groups vs three ages vs two visual conditions ANOVA of repeated measures and two groups vs three ages conditions ANOVA.

Variable	Effect	F	df	p	Effect size (η^2)	Post-Hoc	p
COP surface area [mm]	Gr vs Age vs Vc	0.53	2, 99	0.529	0.01		
	Gr vs Age	0.58	2, 99	0.556	0.01		
	Gr vs Vc	3.34	1, 99	0.077	0.03		
	Age vs Vc	7.87	2, 99	0.001	0.13	G1,G2,NG1,NG2: EO < EC	< 0.01
	Age	30.45	1, 99	0.000	0.38	G1,NG1 > G2,G3,NG2,NG3	< 0.01
	Gr	6.34	1, 99	0.013	0.06	G < NG	0.028
	Vc	49.45	1, 99	0.000	0.33	EO < EC	0.001
Average	Gr vs Age	3.38	2, 97	0.038	0.07	NG1 > NG2,NG3,G1,G2,G3,	< 0.01
Achievement	Gr	6.97	1, 97	0.009	0.07	G < NG	0.012
Time Index [s]	Age	10.79	2, 97	0.000	0.18	G1,NG1 < G2,G3,NG2,NG3	< 0.01

Legend: COP – center of pressure; Gr – group; Vc – visual control, NG – non-gymnasts, G – gymnasts, (NG/G)1 – 8-10 years old, (NG/G)2 – 12-14 years old, (NG/G)3 – 18-24 years old, EC – eyes closed, EO – eyes opened, ns – not significant

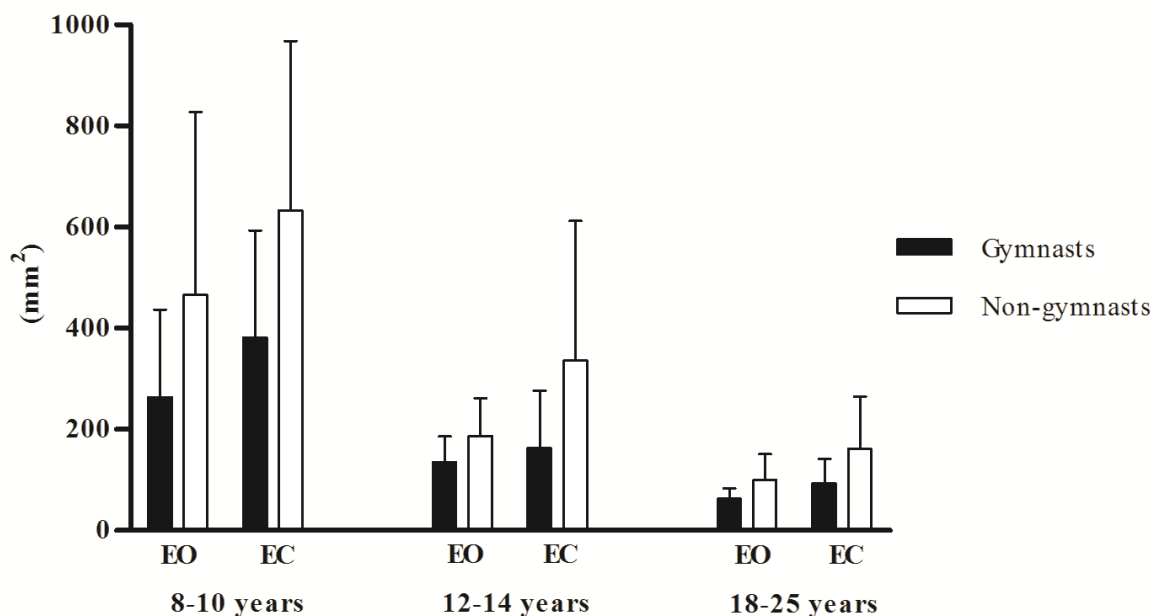

Figure 2. Postural control with both eyes open (EO) and eyes closed (EC).

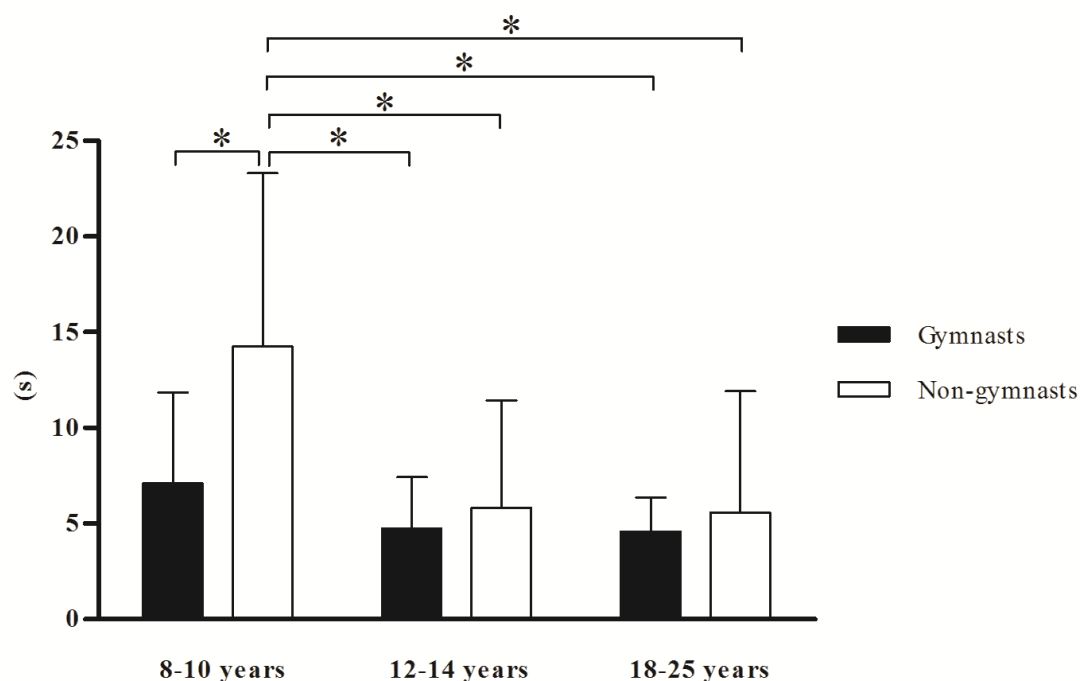

Figure 3. Interaction between the *group* and the *age* factors.

DISCUSSION

Analysis of research results allows to extend the existing knowledge of the development of the postural control in gymnasts and non-training persons. They point to a great differentiation of all measured indices in eyes open, eyes closed, and visual feedback trials. In the study, non-gymnasts and those training artistic gymnastics, regardless of their age and sports level, were characterized by the coefficient of variation at the level of 15-60%. These results allow making a statement about a highly individualized nature of the body balance function during the ontogenetic development between 8-25 years of age.

A similar study of influence of gymnastic training on the static balance control was performed by Garcia et al. (2011), although they investigated female gymnasts and girls at the age of 5-11, while our study consisted of male gymnasts and controls at the age from 8 to 25 years. They found that the youngest group of non-gymnasts (5-7 years old) had significantly worse performance of static bipedal posture

in comparison to older peers (9-11 years old) and gymnasts of both ages. The older groups of gymnasts and non-gymnasts did not differ, which was also noticed in study of Hernández Suárez, Guimaraes Ribeiro, Hernández Rodríguez, Rodríguez Ruiz, and García Manso (2013). In our study the difference between youngest male gymnasts and non-athletes (8-10 years old) did not reach significance, although it was close to it. Moreover, both gymnasts' and controls' performance was significantly worse in comparison to gymnasts and adolescents at age of 12-14 years and adults.

The influence of the *vision* factor on static postural control was significant in our youngest (8-10 years old) groups of gymnasts and non-gymnasts. Their static balance performance was better in eyes open condition. In compare, studies on younger female groups showed that at the age of 5-7 years only gymnasts were able to effectively use their visual control to improve performance of static quiet stance (Garcia et al., 2011) . This same study

showed that both gymnasts and non-gymnasts aged 9–11 years were not influenced by a lack of vision and their performance was similar both with eyes opened and closed. However, our study could not confirm that in the middle group (12–14 years old), a lack of vision did not have an impact only on the performance of gymnasts. Although, it should be noted that our study consisted of male gymnasts and controls while the one mentioned above investigated females. However, it has been shown that boys exhibit a lag in terms of developing postural control (Roepke, Smith, Ronnekleiv, & Kelly, 2012; Steindl, Kunz, Schrott-Fischer, & Scholtz, 2006). Especially up to the age of 12, girls show better postural control than boys (Roepke et al., 2012).

Moreover, static postural control of 12–14-year-old gymnasts was similar to both groups of adults regardless of vision conditions. The same lack of impact of vision on the level of static balance performance within adult gymnasts and other non-gymnast athletes were previously reported (Asseman et al., 2004; Vuillerme, Teasdale, et al., 2001).

Such results suggest that adults develop their static balance abilities to the extent where a lack of vision is compensated by the other senses and such development can be facilitated through gymnastic training. The results of the present analysis confirm observations of other authors engaged in research with a use of the posturographic method that static postural control in conditions of relative peace among the youth and adults gymnasts does not fully reflect their balance capabilities (Asseman et al., 2004; Hernández Suárez et al., 2013; Vuillerme, Teasdale, et al., 2001).

According to Davlin-Pater (2010), level of dynamic postural control development could be evaluated, among others, by biofeedback posturographic tests. Such test was proposed in our study in contrast to unspecific static bipedal condition. Results in dynamic postural control with visual feedback were comparable to those in static conditions with eyes opened, thus the

impact of gymnastic training was only visible for children at the age from 8 to 10 years. It also may indicate that during the early-school period systematic participation in gymnastics training which includes exercises based on joint position and force sense can increase the ability to coordinate and regulate body posture. Considering dynamic postural control, Vuillerme, Teasdale, et al. (2001) showed that adult gymnasts demonstrated better performance in reweighting proprioceptive information in comparison to other athletes. Moreover, Taniewski et al. (2001) investigated impact of stimulating vestibular organ by rotation of the body in the longitudinal axis among gymnasts and non-athletes. It has been shown that after a stimulation gymnasts who were characterized by better results of the COP surface area prior to the excitation of the vestibular organ also had better results after its stimulation, as well as that difference between gymnasts and non-athletes were increasing with age of participants. Other studies showed that after perturbation of the body in the sagittal plane, highly qualified gymnasts stood out with much quicker recovering balance than non-training subjects. Moreover, in gymnasts during stabilizing the body posture the most distinct movements were recorded in the knee joints, while non-gymnasts used their hips for this purpose, showing the training influence on strategy of maintaining body balance (Gautier, Thouwarecq, & Larue, 2008). Gautier, Thouwarecq, and Chollet (2007) and Vuillerme and Nougulier (2004), point to the need to monitor changes in postural control that occur in athletes under the influence of specific exercises, systematically applied in training. Our study showed that both unspecific static as well as dynamic postural control with visual feedback are affected by gymnastic training, mainly in early years of human development. The limitation of the study is that the static and dynamic tasks used in the research did not fully represent adult gymnasts' capabilities of postural control. This was due to the fact that the tests included in the study were chosen so

that they could be performed by both professional gymnasts and untrained children. However, more complex or more specific postural tasks could be useful in investigating and showing adult gymnasts' postural control potential.

CONCLUSIONS

Results may suggest that both static postural control in unspecific bipedal conditions and dynamic postural control in visual feedback conditions, after developing them, are at a similar level despite gymnastic training, although training can accelerate the development of such abilities in children and early adolescents. While the unspecific static bipedal and dynamic with visual feedback tests do not reflect the capabilities of postural control in adult gymnasts, other more sport-specific tests should be incorporated for them.

ACKNOWLEDGEMENT

This scientific work was funded under the program of Polish Ministry of Science and Higher Education under the name "Development of Academic Sport" in years 2015-2017 Project No. 0018/RS3/2015/53. The funding organization does not affect the study results.

REFERENCES

- Andersson, G., Hagman, J., Talianzadeh, R., Svedberg, A., & Larsen, H. C. (2002). Effect of cognitive load on postural control. *Brain Res Bull*, 58(1), 135-139.
- Asseman, F., Caron, O., & Cremieux, J. (2004). Is there a transfer of postural ability from specific to unspecific postures in elite gymnasts? *Neurosci Lett*, 358(2), 83-86. doi: 10.1016/j.neulet.2003.12.102
- Asseman, F. B., Caron, O., & Cremieux, J. (2008). Are there specific conditions for which expertise in gymnastics could have an effect on postural control and performance? *Gait Posture*, 27(1), 76-81. doi: 10.1016/j.gaitpost.2007.01.004
- Bairstow, P. J., & Laszlo, J. I. (1981). Kinaesthetic sensitivity to passive movements and its relationship to motor development and motor control. *Dev Med Child Neurol*, 23(5), 606-616.
- Carrick, F. R., Oggero, E., Pagnacco, G., Brock, J. B., & Arian, T. (2007). Posturographic testing and motor learning predictability in gymnasts. *Disabil Rehabil*, 29(24), 1881-1889. doi: 10.1080/09638280601141335
- Cody, K. A., & Nelson, A. J., Jr. (1978). The effect of verticality perception on body balance in normal subjects. *Phys Ther*, 58(1), 35-41.
- Croix, G., Chollet, D., & Thouvarecq, R. (2010). Effect of expertise level on the perceptual characteristics of gymnasts. *J Strength Cond Res*, 24(6), 1458-1463. doi: 10.1519/JSC.0b013e3181d2c216
- Dallas, G., Dallas, C., Theodo, A., & Papouliakos, S. (2016). Effects of ankle joint injuries on balance in male and female gymnasts. *Biology of Exercise*, 12(1), 69-85.
- Davlin-Pater, C. (2010). The effects of visual information and perceptual style on static and dynamic balance. *Motor Control*, 14(3), 362-370.
- Freeman, M. L., & Broderick, P. (1996). Kinaesthetic sensitivity of adolescent male and female athletes and non-athletes. *Aust J Sci Med Sport*, 28(2), 46-49.
- Fujisawa, N., Masuda, T., Inaoka, Y., Fukuoka, H., Ishida, A., & Minamitani, H. (2005). Human standing posture control system depending on adopted strategies. *Med Biol Eng Comput*, 43(1), 107-114.
- Garcia, C., Barela, J. A., Viana, A. R., & Barela, A. M. (2011). Influence of gymnastics training on the development of postural control. *Neurosci Lett*, 492(1), 29-32. doi: 10.1016/j.neulet.2011.01.047
- Gautier, G., Thouvarecq, R., & Chollet, D. (2007). Visual and postural control of an arbitrary posture: the handstand. *J Sports Sci*, 25(11), 1271-1278. doi: 10.1080/02640410601049144

Gautier, G., Thouvaecq, R., & Larue, J. (2008). Influence of experience on postural control: effect of expertise in gymnastics. *J Mot Behav*, 40(5), 400-408. doi: 10.3200/JMBR.40.5.400-408

Gautier, G., Thouvaecq, R., & Vuillerme, N. (2008). Postural control and perceptive configuration: influence of expertise in gymnastics. *Gait Posture*, 28(1), 46-51. doi: 10.1016/j.gaitpost.2007.09.007

Geldhof, E., Cardon, G., De Bourdeaudhuij, I., Danneels, L., Coorevits, P., Vanderstraeten, G., & De Clercq, D. (2006). Static and dynamic standing balance: test-retest reliability and reference values in 9 to 10 year old children. *Eur J Pediatr*, 165(11), 779-786. doi: 10.1007/s00431-006-0173-5

Harringe, M. L., Halvorsen, K., Renström, P., & Werner, S. (2008). Postural control measured as the center of pressure excursion in young female gymnasts with low back pain or lower extremity injury. *Gait Posture*, 28(1), 38-45.

Hernández Suárez, M., Guimaraes Ribeiro, D., Hernández Rodríguez, J., Rodríguez Ruiz, D., & García Manso, J. M. (2013). The effect of early systematic gymnastic training on postural control. *Br J Sports Med*, 47, 31-32.

Iatridou, K., Mandalidis, D., Chronopoulos, E., Vagenas, G., & Athanasopoulos, S. (2014). Static and dynamic body balance following provocation of the visual and vestibular systems in females with and without joint hypermobility syndrome. *J Bodyw Mov Ther*, 18(2), 159-164. doi: 10.1016/j.jbmt.2013.10.003

Kavounoudias, A., Gilhodes, J. C., Roll, R., & Roll, J. P. (1999). From balance regulation to body orientation: two goals for muscle proprioceptive information processing? *Exp Brain Res*, 124(1), 80-88.

Kochanowicz, K. (2010). *Podstawy kierowania procesem szkolenia sportowego w gimnastyce [The basis of directing of sports training process in gymnastics]*: AWFIS Gdańsk.

Kochanowicz, K., Boraczyńska, L. B., & Boraczyński, T. (2009). Quantitative and qualitative evaluation of motor coordination abilities in gymnast girls aged 7-9 years. *Balt. J. Health Phys. Act.*, 1, 62-70.

Marin, L., Bardy, B. G., & Bootsma, R. J. (1999). Level of gymnastic skill as an intrinsic constraint on postural coordination. *J Sports Sci*, 17(8), 615-626. doi: 10.1080/026404199365641

Roepke, T. A., Smith, A. W., Ronnekleiv, O. K., & Kelly, M. J. (2012). Serotonin 5-HT_{2C} receptor-mediated inhibition of the M-current in hypothalamic POMC neurons. *Am J Physiol Endocrinol Metab*, 302(11), E1399-1406. doi: 10.1152/ajpendo.00565.2011

Steindl, R., Kunz, K., Schrott-Fischer, A., & Scholtz, A. W. (2006). Effect of age and sex on maturation of sensory systems and balance control. *Dev Med Child Neurol*, 48(6), 477-482. doi: 10.1017/S0012162206001022

Stemplewski, R., Maciaszek, J., Osiński, W., & Szeklicki, R. (2011). Test-Retest Reliability of Measurements of the Center of Pressure Displacement in Quiet Standing and During Maximal Voluntary Body Leaning Among Healthy Elderly Men. *Journal of Human Kinetics*, 28, 15-23.

Taniewski, M., Zaporozhanow, W., Kochanowicz, K., & Kruczkowski, D. (2001). Functional status of the equilibrium system in athletes as assessed by vestibulo-spinal and vestibulo-ocular reflexes. *Polish J Sport Med*, 6, 227-231.

Teasdale, N., & Simoneau, M. (2001). Attentional demands for postural control: the effects of aging and sensory reintegration. *Gait Posture*, 14(3), 203-210.

Tsopani, D., Dallas, G., Tsiganos, G., Papouliakos, S., Di Cagno, A., Korres, G., Korres, S. (2014). Short-term effect of whole-body vibration training on balance, flexibility and lower limb explosive strength in elite rhythmic gymnasts. *Hum Mov Sci*, 33, 149-158.

Vuillerme, N., & Nouguié, V. (2004). Attentional demand for regulating postural sway: the effect of expertise in gymnastics. *Brain. Research*, 63, 161-165.

Vuillerme, N., Danion, F., Marin, L., Boyadjian, A., Prieur, J. M., Weise, I., & Nougier, V. (2001). The effect of expertise in gymnastics on postural control. *Neurosci Lett*, 303(2), 83-86.

Vuillerme, N., Teasdale, N., & Nougier, V. (2001). The effect of expertise in gymnastics on proprioceptive sensory integration in human subjects. *Neurosci Lett*, 311(2), 73-76.

Winter, D. A. (1995). Human balance and posture control during standing and walking. *Gait Posture*, 3 193-214.

Corresponding author:

Andrzej Kochanowicz
Gdańsk University of
Physical Education and Sport
Kazimierza Gróskiego 1
80-339 Gdańsk,
Poland
Phone: +48 58 554 74 00
e-mail: andrzejkochanowicz@o2.pl

EFFECTS OF A RECREATIONAL GYMNASTICS PROGRAM ON THE MOTOR PROFICIENCY OF YOUNG CHILDREN

Nafsika Karachle, Aspasia Dania, Fotini Venetsanou

School of Physical Education and Sport Science, National and Kapodistrian University, Athens,
Greece

Original article

Abstract

A high level of Motor Proficiency (MP) in early years is associated with successful functioning within daily life and participation in physical activity both in short and long term. Therefore, the investment in movement programs that can boost the MP of young children is of great importance. The aim of the present study was to investigate the effect of a 6-month Recreational Gymnastics (RG) program on the MP of young children. Thirty-four children from Athens, Greece, aged 3-7 years (4.7±1.2 years) volunteered to participate in the research. Among them, 21 constituted the experimental group (EG) and attended the RG program, while 13 were allocated to the control group (CG) and did not participate in any organized form of physical activity. Pre and post measurements were conducted in both groups with the short form of the Bruininks-Oseretsky Test of Motor Proficiency – Second Edition (Bruininks & Bruininks, 2005). The ANOVA with repeated measures that was applied revealed that although both groups improved significantly their MP between the two measurements ($p < .001$), the EG significantly surpassed the CG in the post-measurement ($p < .05$). According to the above, it can be concluded that RG can be an effective means for the MP enhancement in early childhood.

Keywords: motor proficiency, recreational gymnastics, young children, BOT-2.

INTRODUCTION

Early childhood is considered as an ideal age period for the development of fundamental movement skills (Gallahue, Ozmun, & Goodway, 2012) that constitute the basis for both the skills needed for successful functioning within daily life and specialized movement skills required for the participation in physical activity (PA) and sports (Piek, Hands, & Licari, 2012). Qualitatively different aspects of gross and fine motor performance synthesize Motor Proficiency (MP), an index of motor development (Bruininks, 1978) that seems to be important for PA participation (Kambas et al., 2012; Rivilis, Hay, Cairney, Klentrou, Liu, & Faught., 2011). According

to research carried in this field, a high level of MP during the first years of life is associated with high levels of PA (Cliff, Okely, Smith, & McKeen, 2009; D'Hondt, Deforche, De Bourdeaudhuij, & Lenoir, 2009; Fisher et al., 2005; Graf et al., 2004; Kambas et al., 2012; Williams et al., 2008).

Being influenced by various environmental factors (e.g. family features, such as socioeconomic status, parents' educational level, interactions among its members; schooling; socio-cultural context; participation in intervention movement programs) (Venetsanou & Kambas, 2010), MP is enhanced as children are offered opportunities to expand their skill repertoire

and refine the quality of their movements (Cleland & Gallahue, 1993). Relative research proves that participation in developmentally appropriate movement programs brings significant positive effects on the MP of young children (Bellows, Davies, Anderson, & Kennedy, 2013; Deli, Bakle, & Zachopoulou, 2006; Venetsanou & Kambas, 2004; Venetsanou, Kambas, Sagioti, & Giannakidou, 2009), enhancing in that way children's health (Venetsanou, Kambas & Giannakidou, 2015).

These assertions are extremely significant, especially nowadays, when children receive limited opportunities for participation in free PA (Venetsanou et al., 2015) and the investment in preschool training programs that could boost the MP of children remains a global concern of great importance (Cohen, Morgan, Plotnikoff, Callister, & Lubanset, 2014).

In that direction, Gymnastics can play a significant role as it is considered to be an excellent means for teaching movement skills and promoting health related fitness (Coelho, 2010; Corbin, Pangrazi & Franks, 2000). Research findings confirm that the participation in gymnastics programs results in MP improvement (Culjak, Miletic, Kalinski, Kezic, & Zuvela, 2014; Fallah, Nourbakhsh & Bagherly, 2015; Garcia, Barela, Viana, & Barela, 2011), and also brings benefits on children's skeletal development (Burt, Ducher, Naughton, Courteix, & Greene, 2013) and social behavior (Al-Awamleh, 2010).

Recreational Gymnastics (RG), being an activity for all children and not a sport only for the talented few, can offer many benefits to its participants in a fun and creative way (Lulla, 2011). As it is the case in other countries, also in Greece, RG programs hold a prominent place within physical education or sports training curricula as a form of exercise aiming to promote students' holistic development. In recent years, more and more Greek children as young as three years old, enroll in RG programs. However, there is still paucity of research in this area especially in regard of

studies that examine the effects of RG programs on the MP of young children.

Therefore, the aim of the present study was to investigate the effect of a 6-month RG program on the MP of children aged 3-7 years, hypothesizing that children who participate in such a program (experimental group) will improve their MP more than children who do not participate systematically in any kind of exercise (control group).

METHODS

Thirty-four children (5 boys and 29 girls), aged between 3-7 years ($M= 4.7$ years, $SD= 1.2$) participated in the study. All the participants lived in Glyfada, Attica, Greece, and had no previous experience in RG. Among them, 21 were just enrolled in RG classes organized by two local gymnastics clubs in Athens and were allocated to the Experimental Group (EG).

In order for the influence of the RG program on children's MP to be examined, we tried to find children of the same age with the EG who did not participate in any extracurricular movement program. These children would constitute the Control Group (CG). For this purpose, the first author visited six preschool settings of the municipality of Glyfada and informed preschool educators and parents about the purpose of the study. Through this process, 13 children volunteered to participate. These children were allocated to the CG and participated only in the activities determined by the Greek Kindergarten Curriculum.

For the measurement of the MP of children the Bruininks-Oseretsky Test of Motor Proficiency, Second Edition (BOT-2) (Bruininks & Bruininks, 2005) was used. The BOT-2 is designed so as to (a) determine the level of MP of youth aged between 4-21 years; (b) detect potential movement difficulties; (c) contribute to the design and evaluation of intervention movement programs (Bruininks & Bruininks, 2005). In the present study, the short version of the battery (BOT-2 SF) was used.

The BOT-2 SF includes the following 14 items drawn from the 53 items of the BOT long form: drawing a line on a zig-zag path; folding a paper; copying a square; copying a star; transferring pennies; dropping and catching a ball; dribbling a ball; jumping in place; tapping feet and fingers; walking forward on a line; standing on balance beam; one leg stationary hop; knee push-ups; sit-ups.

The time required for the administration of the BOT-2 SF is approximately 20 minutes. During the assessment, the raw score of the performance of the examinee on each item is recorded on the evaluation form. The 14 raw scores are converted into point ones, ranging from two to 13, which are added to compile the total battery point score. Normative data, provided in the BOT-2 manual, can be used in order for standard scores and percentiles ranks to be estimated (Bruininks & Bruininks, 2005). In the present study, the total BOT-2 SF point score was used.

The technical adequacy of the battery is sufficiently supported by several research findings (Bruininks & Bruininks, 2005; Lucas et al., 2013; Wuang & Su, 2009), while, as far as the Greek population is concerned, there is sufficient evidence supporting both the test – retest reliability (Mitsios, Voukias & Venetsanou, 2016) and the construct validity (Voukias, Zavolas, Mitsios, & Venetsanou, 2015; Voukias, Zavolas, Voukia, Venetsanou, & Karaiskos, 2014) of the BOT-2 SF.

Pre-and-post measurements with the BOT-2 SF were administered in September 2015 and April 2016 respectively, with the pre- measurement taking place before the start of the RG program and the post one immediately after the end of the program. Both measurements were conducted indoors for each group separately, in the sports clubs for the EG and in classrooms of the kindergartens for the CG. Each child was tested individually from expertly trained users of the BOT test battery. Written parental consent was given for all children's participation in the study.

The RG program applied in the present study was based on the pedagogical approach of Psychomotor Education, according which children are given multiple opportunities to choose their way of action while moving their body and improving their motor-perceptual skills (Zimmer, 2006). The skills practiced within the RG program were classified in three major categories: locomotor, non-locomotor and orientation skills. Based on the principles of movement education (Laban, 1980) and the guidelines for the design and implementation of high quality physical education programs (National Association for Sports and Physical Education-NASPE, 2004), the learning outcomes of the RG program focused on children's:

- Physical development – at the level of motor abilities like coordination, flexibility, agility, muscle strength, endurance and bone strength.
- Movement competence – at the level of understanding and performance of general categories of body movement i.e. travelling, weight transfer, balance, jumping - landing and rotation, all being developed with an emphasis on the concepts of space, effort and relationships.
- Cognitive development – with an emphasis on exploration, problem solving and decision making.
- Social development – with a focus on partner and group work, peer tutoring and assessment.

Taking in mind the individual differences among children and the within-group heterogeneity of learning styles, pretend play, music and team games were included as teaching aids, in order to encourage individual expression, self-awareness and social interaction between the EG participants (Lindqvist, 2001; Mosston & Ashworth, 2002).

The program was applied for a 6-month period, twice a week (from September 2015 to April 2016). Each RG lesson lasted one hour and 30 minutes.

The data were analyzed with a 2 (groups) x 2 (measures) analysis of variance (ANOVA), with repeated measures on the

second factor. Post hoc analyses were also conducted with the use of the Bonferroni test, with alpha set at .05.

Moreover, in order to further strengthen the results of the study, an analysis of covariance (ANCOVA) was also used, with the two groups' post-test total BOT-2 SF scores as the dependent variable and their pre-test measurement as the covariate variable. All analyses were carried out with the SPSS 22 statistical package.

RESULTS

Means and standard deviations for the pre and post-test measurements of both groups are shown in Table 1. The Kolmogorov-Smirnov test that was applied revealed that the data were normally distributed. From the results of the ANOVA it was found that the group by measurement interaction was not statistically significant ($F_{1,32} = 4.031, p = .053$), while as regards the main effects of the two factors, they were both significant ($F_{1,32} = 86.49, p = .000, \eta^2 = .73$ and $F_{1,32} = 5.83, p = .022, \eta^2 = .154$ for "measure" and "group", respectively).

Table 1.
Means and Standard Deviations for BOT-2 SF Total Scores by Measurement and Group .

Group	Pre Measurement	Post Measurement
Control	27.15 ± 12.6	35.08 ± 11.55
Experimental	35.71 ± 13.5	48 ± 13.5
Total	32.44 ± 13.63	43.06 ± 14.11

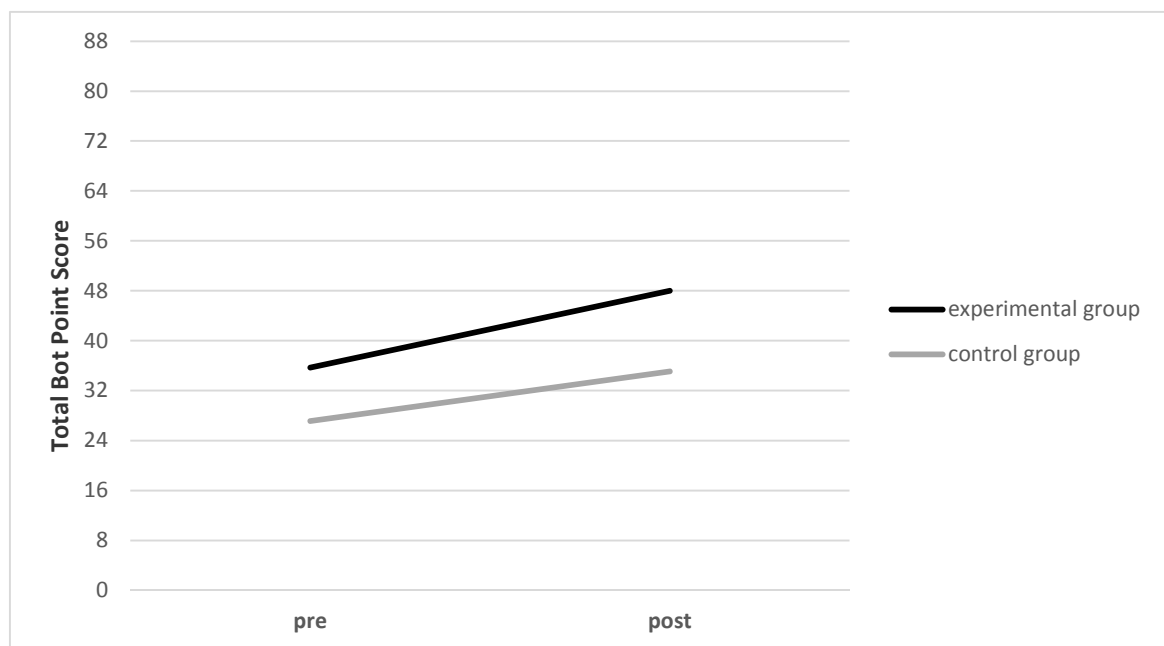

Figure 1. Total BOT Score of Experimental and Control Group in Pre and Post Measurements.

Specifically, all participants improved their performance between the two time points (pre and post) (Mean Difference = 10.104, $p = .000$). This developmental trend was also evident in each group's intra-test

performance, with both the CG (Mean Difference = 7.9, $p = .000$) and the EG (Mean Difference = 12.3, $p = .000$) showing a statistically significant improvement of their MP (Figure 1).

As far as the comparison between the two groups in each measurement is concerned, it was found that in the pre-test measurement, there were no statistically significant differences between their total BOT-2 SF scores (Mean Difference= 8.56, $p = .075$), although the EG had higher scores than the CG. On the contrary, during the second measurement, the MP difference between the two groups proved to be statistically significant (Mean Difference= 12.92, $p = .007$).

From the results of the ANCOVA it was revealed that the factor "group" had a statistically significant impact on children's MP ($F_{1,31} = 6.24$, $p = .018$, $\eta^2 = .17$), after controlling for the effect of the pre-test ($F_{1,31} = 115.41$, $p = .000$, $\eta^2 = .79$).

DISCUSSION

The present study assessed the impact of a 6-month RG program on the MP of children aged 3-7 years. Pre-and-post measurements were administered to all research participants, in order to determine whether the indices of MP in the EG would be better than those of the CG, as a result of the program.

From the results it was revealed that the performance indices of both groups on the BOT-2 SF were improved between the two measurements. This was an expected finding attributed to the process of biological maturation during the six-month period of the research. According to relative research, age is a mediator of the maturation and performance in children that can play a determinant role in their motor development, allowing alterations to occur rapidly (Butterfield, Lehnhard, & Coladarci, 2002; Delaš, Miletić, & Miletić, 2008; Fisher et al., 2005; Gallahue & Ozmun 2005).

However, researchers agree that motor development is further enhanced when children grow in supportive learning environments that offer multiple opportunities for participation in developmentally appropriate activities (Akin, 2013; Al-Awamleh, 2010; Božanić,

Kalinski, & Žuvela, 2011; Culjak et al., 2014; Fallah et al., 2015). In the present study, the noticeable improvement of the EG group in the post-test measurement provided evidence regarding the significant impact of contextual factors on the MP in young children. The differences between the two groups were not statistically significant at the beginning of the intervention, but they became noticeable at the end of the program. It seems that the RG program significantly contributed to the development of the MP of children in the EG.

Similar findings are reported in relevant research projects that used RG as a means for improving various indices of motor performance in young children, such as fundamental movement skills (Akin, 2013; Culjak et al., 2014), body control (Garcia et al., 2011) and fitness (Lyulina, Zakharova, & Vetrova, 2013). The former attributes are considered as potential indicators of health and robustness in youth, since they are connected with movement economy, enhanced strength and endurance capabilities, as a result of putting less effort on every given task (Lloyd, Colley & Tremblay, 2010; Trajković, Madić, Sporiš, Aleksić-Veljković & Živčić-Marković, 2016). Therefore, the integration of physical fitness parameters within movement programs should be considered with great attention by curriculum developers, especially within early childhood education where a foundational level of skills and abilities should be expected by all children. In this direction, RG programs can be used as a suitable and effective means, especially when they are designed according to children's developmental needs and are implemented by expert physical education teachers within appropriate training sessions.

As it was proven by the intra-performance improvement of the CG, free play can also have a positive impact on the motor development of young children (Corrie & Barratt-Pugh, 1997). However, this impact is lower compared to the impact of purposefully organized exercise programs as the RG program of the present study. The

latter was structured purposefully with an emphasis on promoting the needs and abilities of the particular group. The course content covered a wide range of topics that addressed physical capacities (e.g. strength, postural control, and flexibility), cognitive attributes (e.g. recall, memory, concentration) and psycho-social skills (e.g. self-expression, communication, and acceptance).

Within a non-competitive and inclusive learning environment of fun and enjoyment, children were encouraged by their physical education teacher to reach their full potential and increase their skill level and abilities. Relevant studies have shown that multiple benefits can be achieved when children participate in movement programs that are designed so as to maximize fun, communication and understanding during the process of motor learning. Music/movement programs (Venetsanou & Kambas, 2004), psychomotor education and creative movement programs (Bhatia, Davis, & Shamas-Brandt, 2015; Kouli et al., 2010; Venetsanou et al., 2009; Wang, 2003; Yarimkaya & Ulucan, 2014), or preschool physical education programs (Bellows et al., 2013), all can act as mediators in the personal and social skill development of young children. The pedagogical value of such programs lies on their offering of an enjoyable and educational approach to movement, one that supports well-being and development of children in all levels (Fisher et al., 2005; Graf et al., 2004; Williams et al., 2008).

This study has some limitations that should be noticed. The small sample size and the fact that all the participants lived in the same city should be considered when interpreting the findings from this study. If the effect of the RG on children's MP is to be thoroughly investigated, more studies, recruiting larger samples from several geographical areas, are needed. However, besides its limitations, this study provides evidence about the effectiveness of RG programs for the optimal development of young children's motor proficiency. Considering that a low level of movement

skills during the first years of life interferes with normal motor and social development and reduces opportunities for children to feel competent and autonomous in their everyday living (Cliff et al., 2009; D'Hondt et al., 2009; Fisher et al., 2005; Graf et al., 2004; Williams et al., 2008; Wrotniak, Epstein, Dorn, Jones, & Kondilis, 2006), yet it is understood that participation in such programs should be encouraged.

As contexts for providing developmentally appropriate movement instruction, RG programs can encourage young children to successfully experience the benefits of a physically active and healthy lifestyle. However, before such claims can be supported with greater certainty, future studies, examining the impact of RG programs on physical, cognitive and affective parameters of the development of children, are needed.

REFERENCES

- Al-Awamleh, A. (2010). *The effectiveness of using educational gymnastics skills on motor capabilities and social behavior among kindergarten children*. Unpublished doctoral dissertation, University of Konstanz, Germany.
- Akın, M. (2013). Effect of gymnastics training on dynamic balance abilities in 4-6 years of age children. *International Journal of Academic Research*, 5(2) 142-146.
- Bellows, L. L., Davies, P. L., Anderson, J., & Kennedy, C. (2013). Effectiveness of a physical activity intervention for Head Start preschoolers: a randomized intervention study. *American Journal of Occupational Therapy*, 67(1), 28-36.
- Bhatia, P., Davis, A., & Shamas-Brandt, E. (2015). Educational gymnastics: The effectiveness of Montessori practical life activities in developing fine motor skills in kindergartners. *Early Education and Development*, 26(4), 594-607.
- Božanić, A., Kalinski, S. D., & Žuvela, F. (2011). *Changes in fundamental movement skills caused by a gymnastics treatment in preschoolers*. In *Proceedings of*

the 6th Congress FIEP-a Europe "Physical Education in the 21st century – pupils' competencies, 89-94. Porec, Hrvatska.

Bruininks, R. H. (1978). *The Bruininks – Oseretsky test of motor proficiency: examiner's manual*. Circle Pines, MN: American Guidance Service.

Bruininks, R. H. & Bruininks, B. D. (2005). *Bruininks-Oseretsky test of motor proficiency-second edition*. Minneapolis: MN Pearson.

Burt, L. A., Ducher, G., Naughton, G. A., Courteix, D., & Greene, D. A. (2013). Gymnastics participation is associated with skeletal benefits in the distal 70 forearm: a 6-month study using peripheral Quantitative Computed Tomography. *Journal of Musculoskeletal and Neuronal Interactions*, 13(4), 395-404.

Butterfield, S. A., Lehnhard, R. A., & Coladarci, T. (2002). Age, sex, and body mass index in performance of selected locomotor and fitness tasks by children in grades K-2. *Perceptual and Motor Skills*, 94(1), 80-86.

Cleland, F., & Gallahue, D. (1993). Young children's divergent movement ability. *Perceptual and Motor Skills*, 77(2), 535-544.

Cliff, D., Okely, A., Smith L., & McKeen L. (2009). Relationships between fundamental movement skills and objectively measured physical activity in preschool children. *Pediatric Exercise Science*, 21, 436-449.

Coelho, J. (2010). Gymnastics and movement instruction: Fighting the decline in motor fitness. *Journal of Physical Education, Recreation & Dance*, 81(1), 14-18.

Cohen, K. E., Morgan, P. J., Plotnikoff, R. C., Callister, R., & Lubanset, D. R. (2014). Fundamental movement skills and physical activity among children living in low-income communities: a cross-sectional study. *International Journal of Behavioral Nutrition and Physical Activity*, 11, 49-58.

Corbin, C. B., Pangrazi, R. P., & Franks, B. D. (2000). Definitions: Health, fitness and physical activity. *President's*

Council on Physical Fitness and Sports Research Digest, 3(9), 1-8.

Corrie, L., & Barratt-Pugh, C. (1997). Perceptual-motor programs do not facilitate development: Why not play? *Australian Journal of Early Childhood*, 22(1), 30-35.

Culjak, Z., Miletic, D., Kalinski, S. D., Kezic, A., & Zuvela, F. (2014). Fundamental movement skills development under the influence of a gymnastics program and everyday physical activity in seven-year-old children. *Iranian Journal of Pediatrics*, 24(2), 124.

Delaš, S., Miletić, A., & Miletić, Đ. (2008). The influence of motor factors on fundamental movement skills: the differences between boys and girls. *Facta Universitatis. Series: Physical Education and Sport*, 6(1), 31-39.

Deli, E., Bakle, I., & Zachopoulou, E. (2006). Implementing intervention movement programs for kindergarten children. *Journal of Early Childhood Research*, 4(1), 5-18.

D'Hondt, E., Deforche, B., De Bourdeaudhuij, I., & Lenoir, M. (2009). Relationship between motor skill and Body Mass Index in 5- to 10-year-old children. *Adapted Physical Activity Quarterly*, 26, 21-37.

Fallah, E., Nourbakhsh, P., & Bagherly, J. (2015). The effect of eight weeks of gymnastics exercises on the development of gross motor skills of five to six years old girls. *European Online Journal of Natural and Social Sciences*, 4(1s), 845.

Fisher, A., Reilly, J. J., Kelly, L. A., Montgomery, C., Williamson, A., Paton, J. Y., et al. (2005). Fundamental movement skills and habitual physical activity in young children. *Medicine and Science in Sports and Exercise*, 37(4), 684-688.

Gallahue, D. L., & Ozmun, J. C. (2005). *Understanding motor development: Infants, children, adolescents, adults* (6th ed). Iowa: McGraw-Hill.

Gallahue, D., Ozmun, J. C., & Goodway, J. D. (2012). *Understanding motor development: Infants, children, adolescents, adults* (7th ed.). New York: McGraw-Hill.

Garcia, C., Barela, J. A., Viana, A. R., & Barela, A. M. F. (2011). Influence of gymnastics training on the development of postural control. *Neuroscience Letters*, 492(1), 29-32.

Graf, C., Koch, B., Kretschmann-Kandel, E., Falkowski, G., Christ, H., Coburger, S., et al. (2004). Correlation between BMI, leisure habits and motor abilities in childhood (CHILT-project). *International Journal of Obesity and Related Metabolic Disorders*, 28(1), 22–26.

Kambas A., Michalopoulou M., Fatouros, I., Christoforidis, C., Manthou, E., Giannakidou, D., et al. (2012). The relationship between motor proficiency and pedometer-determined physical activity in young children. *Pediatric Exercise Science*, 24, 34-44.

Kouli, O., Avloniti, A., Venetsanou, F., Giannakidou, D., Gazi, S., & Kambas, A. (2010). The effect of a psychomotor training program on the motor proficiency of preschool children in a multicultural environment. *European Psychomotricity Journal*, 3(1), 31-36.

Laban, R. (1980). *The mastery of movement* (4th ed.). London: MacDonal and Evans.

Lindqvist, G. (2001). The relationship between play and dance. *Research in Dance Education*, 2(1), 41-52.

Lloyd, M., Colley, R., & Tremblay, M. S. (2010). Perhaps we're riding the wrong animal: advancing the debate on fitness testing for children. *Pediatric Exercise Science*, 22(2), 176-182.

Lucas, B. R., Latimer, J., Doney, R., Ferreira, M. L., Adams, R., Hawkes, G., et al. (2013). The Bruininks-Oseretsky test of motor proficiency-short form is reliable in children living in remote Australian aboriginal communities. *BMC Pediatrics*, 13, 1-12.

Lulla, J. (2011, November/December). Gymnastics. A sport for the talented few or an activity for all? *Technique*, 31(10), 12-14.

Lyulina, N. V., Zakharova, L. V., & Vetrova, I. V. (2013). Effect of complex acrobatic elements in the development of

physical skills of preschool children. *Physical Education of Students*, 4, 59-62.

Mitsios, O., Voukias, K., & Venetsanou, F. (2016). Test-retest reliability of the Bruininks-Oseretsky test of motor proficiency 2-Short form. In *Proceedings of the 24th International Congress on Physical Education and Sport Science "Children and Youth in Physical Activity and Sport"*, 89. Thrace, Greece.

Mosston, M., & Ashworth, S. (2002). *Teaching Physical Education* (5th ed.). San Francisco, CA: Benjamin Cummings.

National Association for Sports and Physical Education (2004). *Physical activity for children: A statement of guidelines for children ages 5-12*. Reston, VA: AAHPERD.

Piek, J., Hands, B., & Licari, M. (2012). Assessment of motor functioning in the preschool period. *Neuropsychology Review*, 22(4), 402-413

Rivlis, I., Hay J., Cairney, J., Klentrou, P., Liu J., & Faight, B. E. (2011). Physical activity and fitness in children with developmental coordination disorder: A systematic review. *Research in Developmental Disabilities*, 32, 894-910.

Trajković, N., Madić, D., Sporiš, G., Aleksić-Veljković, A., & Živčić-Marković, K. (2016). Impact of gymnastics program on health-related fitness in adolescent pupils. *Science of Gymnastics Journal*, 8(2), 157-166.

Venetsanou, F., & Kambas, A. (2004). How can a traditional Greek dances programme affect the motor proficiency of pre-school children? *Research in Dance Education*, 5(2), 127-138.

Venetsanou, F., & Kambas, A. (2010). Environmental factors affecting preschoolers' motor development. *Early Childhood Education Journal*, 37(4), 319-327.

Venetsanou, F., Kambas, A., & Giannakidou, D. (2015). Organised physical activity and health in preschool age: a review. *Central European Journal of Public Health*, 23(3), 200-207.

Venetsanou, F., Kambas, A., Sagioti, E., & Giannakidou, D. (2009). Effect of an

exercise program emphasizing coordination on preschoolers' motor proficiency. *European Psychomotricity Journal*, 2(1), 46-55.

Voukias, K., Zavolas, G., Voukia, C., Venetsanou, F., & Karaikos, L. (2014). Preliminary study of the construct validity of the Bruininks-Oseretsky test of motor proficiency 2-Short form. *Fisiki Agogi & Athlitismos* [Physical Education & Sports], 34(4), 94 (in Greek).

Voukias, K., Zavolas, G., Mitsios, O., & Venetsanou, F. (2015). *Bruininks-Oseretsky test of motor proficiency - Short form 2: Examination of gender bias*. In Proceedings of the 23rd International Congress of Physical Education & Sport, 115. Thrace, Greece.

Wang, H. T. (2003). *The effects of a creative movement program on motor creativity and gross motor skills of preschool children*. Doctoral dissertation, University of South Dakota, USA.

Williams, H. G., Pfeiffer, K. A., O'Neill, J. R., Dowda, M., McIver, K. L., Brown, W. H., et al. (2008). Motor skill performance and physical activity in preschool children. *Obesity*, 16(6), 1421-1426.

Wrotniak, B. H., Epstein, L. H., Dorn, J. M., Jones, K. E., & Kondilis, V. A. (2006). The relationship between motor proficiency and physical activity in children. *Pediatrics*, 118(6), e1758 - e1765.

Wuang, Y. P., & Su, C. Y. (2009). Reliability and responsiveness of the Bruininks-Oseretsky test of motor proficiency-second edition in children with intellectual disability. *Research in Developmental Disabilities*, 30, 847-855.

Yarimkaya, E., & Ulucan, D. D. H. (2014). The effect of movement education program on the motor development of children. *International Journal of New Trends in Arts, Sports & Science Education (IJTASE)*, 4(1).

Zimmer, R. (2006). *Handbuch der Psychomotorik: Theorie und Praxis der psychomotorischen Förderung von Kindern*. Freiburg: Herber.

Corresponding author:

Fotini Venetsanou,
School of Physical Education and Sport
Science,
National and Kapodistrian University
Ethnikis Antistasis 41
Dafni 17237
Greece
e-mail: fvenetsanou@phed.uoa.gr

NUTRITIONAL RECOMMENDATIONS AND GUIDELINES FOR WOMEN IN GYMNASTICS: CURRENT ASPECTS AND CRITICAL INTERVENTIONS

George C. Dallas¹, Costas G. Dallas¹, Evaggelos J. Simatos¹, Jeremy E. Simatos²

¹Kapodistrian University of Athens, School of Physical Education and Sport Science, Athens Greece

²Hellenic Sports Nutrition Research Institute

Original article

Abstract

Pre-adolescent and adolescent gymnasts, and especially artistic gymnasts (AG) and rhythmic gymnasts (RG), belong to a high risk group for severe deficiency in /lack of basic nutrients, especially calcium, iron, folic acid, vitamin D and zinc. The increased demands of accelerated pubertal development in combination with the need to maintain a reduced body mass and the intense daily training (without energy recovery and adequate rest) expose particularly the younger athletes to growth disorders, long-term nutritional deficiencies, problems of emotional nature (low self-esteem, dissatisfaction with body image, multiple daily weighing, obsessions with body aesthetics and physical appearance), hormonal disorders (amenorrhea), premature fatigue, osteopenia, and a particularly increased risk of injury. The vast majority of athletes feel that they are on a constant (chronic) diet. It is typical for athletes to spend hours of daily training with only water intake and no other snack, and coaches are aware of this. The detection and diagnostic assessment of nutritional deficiencies / shortcomings and future nutrition-dependent disorders during the developmental ages of a gymnast is a field of study for every qualified sport dietician. Keeping this in mind, the purpose of this review is to provide targeted nutritional support directions to elite athletes of AG and RG with priority and emphasis on strengthening the immune system, nutritional strategy for direct energy recovery and the control of timely daily food intake during the annual training season.

Keywords: artistic, rhythmic, gymnastics, malnutrition, guidelines, female athlete triad.

INTRODUCTION

At the highest competitive level of AG and RG, the high volume, intensity, frequency and duration of training (6 days/week, 4-6 hours/day) leads athletes to exhaustion especially in cases of double training sessions with a total length of training approaching or surpassing 30 h/w. The age of first engagement usually lies between 5 to 7 years of age, and by age 10 the training level, volume and duration are

intensified (Benardot, 2014; Caine, Russell, & Lim, 2013).

Due to the competitive nature of the sport gymnasts are pre-occupied with their shape, size and/or body weight (which is a competition criterion), while setting high competitive targets often under high pressure for continuous success. According to the literature, the vast majority of athletes of such sports attempt to maintain the

"perfect" physical appearance, which is characterized by low total body mass and low fat mass throughout their sporting career (Beals, 2004). Under conditions of continuous self-control, low self-esteem, rigorous self-criticism and perfectionism they feel the need to constantly show the more disciplined side of themselves: their body become their greatest "achievement". Unfortunately, this situation has become part of the "culture" of these sports and has created a "traditional" behaviour that, in our opinion, is not likely to change.

As a result of these underlying attitudes, fears, insecurities and constant psychological stress, which inundate the young athletes, there is an evolving subclinical form of disordered eating behaviour among high performance athletes (Kerr, Berman, & De Souza, 2006). It is estimated that up to 40-45% of elite athletes in "aesthetic" sports, such as artistic and rhythmic gymnastics, show symptoms of eating disorders (Beals, 2004; Bonci et al., 2008; De Bruin-Oudejans, & Bakker, 2007; De Souza et al., 2014; Ferrand, Champely, & Filaire, 2009; Francisco, Alarcao, & Narciso, 2012; Kerr, Berman, & De Souza, 2006; Nordin, Harris, & Cumming, 2003; Sundgot-Borgen & Garthe, 2011; Torstveit, Rosenvinque, & Sundgot-Borgen, 2008; Wilde, 2013). Therefore, gymnastic sports, by "nature" accelerate the development of the disorder with the "demand" for the acquisition and maintenance of the "perfect" body throughout their whole athletic career.

The combination of various demands, such as the increased need for nutrient intake due to the accelerated pubertal development, the need to maintain a low body mass (and indirectly fat mass), the potentially long-term, poor in nutrients and possibly low energy intake (chronic malnutrition), and the intense hours of daily training requirements (without adequate nutritional intake) expose young athletes to growth disorders, long-term nutritional deficiencies, emotional problems, menstrual disorders (amenorrhoea), premature fatigue, eating disorders, osteopenia and a particularly high risk of injuries (Caine,

Russell, & Lim, 2013; Desbrow et al., 2014; Hoch, Goossen, & Kretschmer, 2008; Meyer & Manore, 2011). All these disorders are central to the pathogenesis of the "female athlete triad", whose main components are: reduced energy availability (with or without eating disorders), menstrual dysfunction and decreased bone density (osteopenia). These components are interrelated in causality, pathogenesis and effects (Ackerman & Madhusmita, 2011; Bahner, 2009; De Souza et al., 2014; Ducher et al., 2011; Sundgot-Borgen et al., 2013; Wilde, 2013; Zach, 2011).

Pre-adolescent and adolescent gymnasts aged 9-18 years that are in the high risk group for severe dietary deficiency, i.e., lack of essential nutrients, are characterized by significantly lower amounts than the recommended daily intakes of calcium, iron, vitamin D and zinc (Benardot, 2014; Cupisti, D'Alessandro, Gastrogiovanni, Barale, & Morelli, 2000; D'Alessandro, Morelli, Evangelisti, Galetta, & Franzoni, 2007; Dallas, Simatos, & Dallas, 2016; Jonnalagadda, Benardot, & Dill, 2000; Jonnalagadda, Bernadot, & Nelson, 1998; Lovell, 2008; Michopoulou et al, 2011; Silva & Paiva, 2015; Soric, Misiqoi-Durakovic, & Pedisis, 2008). In Thompson's (1998) review of five representative surveys of 56 gymnasts, aged 15-18 years, the average daily energy intake was 1789 kcal (or 35,6 kcal/kg). A comprehensive nutritional assessment is the basis for nutritional therapy and for the design of individually set dietary objectives for each athlete. In particular, the nutritional assessment is the first of four stages of the nutritional care process, followed by diagnosis; intervention and dietary control/monitoring (Steinmuller et al, 2014). To this end, a qualified dietitian evaluates the maintenance of the normal development of the body and the good health of the gymnast, identifying predisposing diet-dependent risk factors, detecting malnutrition habits, and timely treating any nutritional deficiencies and/or excess intake (Academy of Nutrition and Dietetics, 2016). In parallel, self-esteem in relation to the

gymnasts' perception of body image should be examined, as low self-esteem is associated with an increased risk of eating disorders and negative perception of body image (Duffy, 2008; Kosmidou, 2014).

A new approach to the interpretation of "malnutrition" and under-reporting

In regards to the applied research methodology on the dietary intake of athletes in "aesthetic" sports, there seems to be an overestimation of the projected energy consumption in both the resting metabolic rate calculations and the energy expenditure. A cause for concern is the wide disparity in the actual energy balance, i.e. the real energy needs of the athletes of these sports. In most dietary assessment surveys, these athletes show a negative energy balance (between 250 and 1200 kcal) with a much reduced energy intake (Deutz, Benardot, Martin, & Cody, 2000). The majority of such studies conclude that the athletes under-report their energy intake. Large discrepancies between the predicted total daily energy expenditure and the actual energy intake (~ 20-35%) have been observed in published nutritional assessment surveys of athletes. However, a number of studies have questioned the validity and reliability of the calculation equations of both the resting metabolic rate (RMR) and the total daily energy consumption of female athletes (Crenshaw, 2009). Thus, sport specific surveys are needed to calculate more accurately the energy consumption of both AG and RG athletes who endure the long hours of daily training. This is in line with Black (2000; 2001), Goldberg & Black (1998).

During growth, energy availability should be in positive balance, beyond the typical daily energy intake needs and the total energy expenditure (basal metabolism + physical activity) because of the higher requirements of accelerated pubertal development and the needs for support and synthesis of new tissue (Desbrow et al, 2014). However, this surplus of available energy cannot be accurately calculated due to the multivariate pubertal development

needs. Crenshaw (2009) found an overestimation of >200 kcal when using equations both for the predictable RMR and the estimated total energy balance. The review of Thompson (1998) also reports a systematic overestimation of the recommended total daily energy intake in adolescents. These differences were mainly attributed to the under-reporting of energy intake by athletes rather than to the indirect calculations for energy expenditure (Crenshaw, 2009). It is reported that especially athletes of "aesthetic" sports, intentionally fail to declare or record lesser amounts of selected intake such as various snacks. Likewise, they may either declare larger quantities of "desirable" food, or temporarily positively alter their nutritional behaviour. The most common recording errors are observed in athletes who are dissatisfied with their body image. One of the reasons for intentionally under-recording energy intake is the fear of disclosing to the researchers (or coaches) improper dietary practices and the need to positively impress the researchers (Beals, 2004; Black, 2001; De Bruin, Oudejans, & Bakker, 2007; Meyer & Manore, 2011). In survey studies, where the recording of dietary intake (with weighed food) was performed under the constant supervision of a qualified dietitian, the under-reporting was significantly reduced. This was verified with the direct calorimetry method via the double labeled water technique using hydrogen and oxygen isotopes. This technique is used to determine, with high accuracy, the energy expenditure of an individual for periods of 1-2 weeks (Driskell & Wolinsky, 2011; Gibson, 2005; Hill & Davies, 2001).

A number of recommendations have resulted despite these issues of validity and reliability. Specifically, Meyer and Manore (2011) suggested energy intake > 45 kcal/kg fat-free mass/day during periods of intense training and pubertal development. Others suggest that the critical threshold for female athletes should be the quotient resulting from the relationship of Energy Intake (EI): RMR > 1.45 and/or > 1.55 (Black, 2000; Goldberg & Black, 1998; Jonnalagadda,

Benardot, & Dill, 2000). Furthermore, using the double labeled water technique, Thompson's (1998) recommendation for overall energy consumption in adolescent girls is ~ 40 kcal/kg or 1.75 times \times RMR. Recently, Dallas, Simatos, & Dallas, (2016) approached the aforementioned reports in relation to the total daily energy balance, and estimated that according to the projected RMR, the body mass of the Greek female gymnasts previously reported (Pavlou, 1992) remained stable [neutral energy balance, EI (7-day): RMR = $\geq 1,6$]. In fact, the planned RMR that Pavlou (1992) proposed coincides with the boundary values proposed by McMurray (2011), i.e. 0.9 kcal/kg/h for females in the general population and 1.15 kcal/kg fat-free mass/h for female athletes. Something similar was concluded in the recent research of Silva & Paiva (2015). It should be noted that corresponding recommendations for male gymnasts have not yet been established.

Predisposing factors of the "Female Athlete Triad" syndrome; A constant threat to the smooth development of an athletic career

It is estimated that one in two young athletes, who engage in sports with emphasis on a thin body, exhibit significantly more food behavioural problems compared to the general population, and to the athletes whose body mass is not a significant performance factor in their sports. In addition, one in five athletes of "aesthetic" sports presents at least two components of the female triad syndrome (reduced energy intake and menstrual dysfunction) and is exposed to an increased risk of injury and other health problems. In a recent survey, Dallas, Simatos & Dallas (2016) reported a large energy deficit in female athletes with their average energy intake not adequately meeting (qualitatively and quantitatively) the nutritional requirements of the corresponding six-hour duration of training. In fact, this applies more to RG. With the longer duration of daily training (~ 8 h) rhythmic gymnasts exhibit a permanently

negative energy balance, especially following afternoon training. This is also confirmed by the survey of Deutz, Benardot, Martin, & Cody, (2000), where large energy deficits (> 300 kcal/h) were associated with a higher percentage of body fat in elite female athletes particularly in RG (Fig. 1).

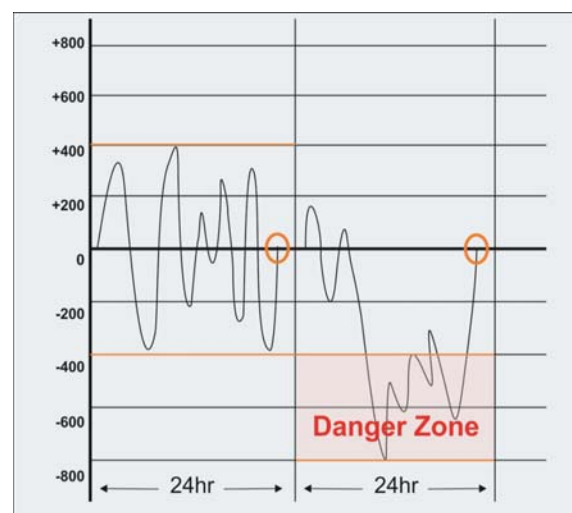

Figure 1. Ideal nutritional standards on left side) and nutritional profile of female gymnasts (on right side); A comparison (Deutz et al, 2000).

The most likely explanation of this phenomenon concerns various homeostatic mechanisms; the reduction in metabolic rate (\downarrow RMR) and adjustable thermogenesis ("survival" mechanism - energy storage), the increased muscle catabolisms, various metabolic and hormonal changes such as a decrease in estrogen, T3, IGF-1, leptin, and an increase of cortisol and endocrine "resistance", as well as a general disruption of the homeostasis of adipose tissue (Benardot, 2014; De Souza & Williams, 2004; De Souza et al., 2014; Deutz, Benardot, Martin, & Cody, 2000; Filaire, Colombier, Beque, & Lac, 2003; Fuqua & Rogol, 2013; Gibbs et al., 2013; Lebenstedt, Platte, & Pirke, 1999; Malina et al., 2013; Rottstein, 2013; Smith, 2000; Trexler, Smith-Ryan, & Norton, 2014; Weimann, Witzel, Schwiderqall, & Bohles, 2000; Weimann, 2002). This situation seems to confirm the overestimation of the predicted daily energy consumption (and/or

expenditure) in the nutritional assessment of gymnasts of AG and even more, of RG. By assessing AG and RG elite athletes, Deutz, Benardot, Martin, & Cody (2000) conclude that within-day energy deficit increased skinfold-derived or DEXA-derived body fat percentage. Their data suggest that despite exercising, the metabolic rate is reduced due to energy deficit. Their findings should discourage athletes from drastically reducing their energy intake and remaining practically without food during their long training sessions, in order to achieve their "ideal" body composition and target body mass.

The reduced daily energy intake (qualitative and quantitative) may cause severe hormonal disorders such as prolactin elevation, which in turn reduces secretion of the hypothalamic gonadotropin-releasing hormone (GnRH) and leads to amenorrhea (Warren & Constantini, 2000). This phenomenon is exacerbated by the demands of an intense physical strain of training (volume, intensity, frequency) done without the required nutritional intake. Therefore, although menstrual disorders have a multifactorial etiology, the main reason is the reduced energy intake (Benson, Engelbert-Fenton, & Eisenman, 1996; Caine, Russell, & Lim, 2013; Dueck, Manore, & Matt, 1996; Gibbs et al., 2013; Malina et al., 2013; Mallinson & de Souza, 2014; Maïmoun et al., 2013; Maïmoun, Georgopoulos, & Sultan, 2014; Roupas & Georgopoulos, 2011; Warren & Perlroth, 2001; Williams, Helmreich, Parfitt, Caston-Balderrama, & Cameron, 2001). At least one in two young athletes engaging in aesthetic sports where particular emphasis is given to the thin body, displays significantly more menstrual cycle disorders (Caine, Russell, & Lim, 2013; Di Cagno et al., 2012; Klentrou & Plyley, 2003; Silva & Paiva, 2015). Indeed, 20-35% of elite gymnasts have primary amenorrhea versus just 1% in the general population (Beals, 2004; Georgopoulos et al., 2002; Maïmoun et al., 2013; Maïmoun, Georgopoulos, & Sultan, 2014; McManus & Armstrong, 2011). Generally, in competitive

gymnastics, later onset of menarche i.e. between 14 and 16 years, is the norm. This can then lead to a delay in bone mineral accretion and deter the attenuation of peak bone mass in the adolescent gymnasts. It is possible a female gymnast of an actual age of 15 years to have a skeletal age of ~ 13 to 13.5 years (Markou et al., 2004). In addition, menstrual dysfunction in athletes has been clearly associated with reduced bone density (Ackerman & Madhusmita, 2011; Caine, Russell, & Lim, 2013; De Souza et al., 2014; Maïmoun et al., 2013; Maïmoun, Georgopoulos, & Sultan, 2014; Markou et al., 2004; Roupas & Georgopoulos, 2011; Sands, Caine, & Borms, 2003; Tournis et al., 2010; Warren & Perlroth, 2001). The paradox is that AG athletes have been found to have an increased rate of osteogenesis and higher bone mass (especially in the hip and spine) than athletes of other sports and of the same age, probably due to the multiple mechanical stimuli of their training (Burt, Greene, Ducher, & Naughton, 2013; Greene & Naughton, 2006; Vicente-Rodriguez et al., 2007).

The most likely interpretation of the increased bone density seen in gymnasts relates to the extremely high level of relative muscle strength (per kg of body mass) that these athletes develop. On the other hand, the increased lean body mass explains, in part, the increased frequency of bone injury because, despite the increased bone density, their bones are functionally and architecturally immature (i.e., growth plate fusion) in relation to muscle strength. Apparently, the large compressive and impact forces / loads that the athletes experience when exercising, are often up to 10 times their weight (exceeding the limit of mechanical bone strength) and causes local accumulated minor injuries mainly in the epiphyses of immature bones (Maffulli, Longo, Spiezia, & Denaro, 2011; Malina et al., 2013). Following hours of intense and monotonous training and increased strain of the musculoskeletal system, the risk of severe acute trauma, chronic overuse syndromes (wrist, lumbar, ankle, etc.), and

stress fractures (Tofler, Stryer, Micheli, & Herman, 1996; Zetaruk, 2000) dramatically increase.

According to research data, a high-level artistic gymnast will miss, due to injuries, up to 21% of the total annual preparation time (frequency > 4 injuries / 1000 h training), i.e. approximately two months. The corresponding frequency of injuries in RG is ≤ 2 injuries / 1000 h training (Kolt & Kirkby, 1999; Caine, Russell, & Lim, 2013). For this reason, although the epidemiological research of the female athlete triad receives strong criticism due to the simultaneous consideration of all 3 parameters of the triad that dramatically reduces the syndrome's occurrence (McManus & Armstrong, 2011) the increased incidents of musculoskeletal injuries in female athletes as a result of the female athlete triad, is no longer being questioned (Barrack et al., 2014; Caine, Russell, & Lim, 2013; De Souza et al., 2014; Roupas & Georgopoulos, 2011; Sundgot-Borgen et al., 2013; Wilde, 2013).

Critical risk factors / special recommendations

1. When assessing nutrition, it is preferable that sport nutritionists use combined techniques for the estimation of the total energy intake and expenditure of the athletes (individually), instead of being based only on indirect calculations and predictions (Burke, 2015; Heaney, O'Connor, Gifford, & Naughton, 2010). In any case, dietary recommendations should consider all parameters: age, sex, type of sport, phases of annual competitive preparation, duration and weekly frequency of training, environmental conditions, nutritional assessment, medical history etc.

2. The daily carbohydrate intake should be increased to ≥ 6 gr/kg in order to ensure optimal glycogen stores, and next day's training should take place within safe energy limits. Female gymnasts have a permanent "deficit" of glycogen due to the long daily and weekly duration of their trainings (Deutz, Benardot, Martin, & Cody, 2000). In our view, it is possible to

gradually and individually raise it up to 20-30% their energy intake (more snacks). It is preferable that a gymnast regularly, timely and in sufficient quantity increases the energy intake rather than her being permanently in energy deficit during the entire day or, even worse, trying to cover the deficit retrospectively.

3. It is proposed that the athlete exhibiting symptoms of the female athlete triad, be considered "injured", with direct intervention (combination of curative measures) and a clear restriction/ban from training and competitions (Sundgot-Borgen et al., 2013; Wilde, 2013).

4. The perceived "pressure" from the coaches, the obsession for a thin body and the constant criticism of the body mass of the athlete cause a "silent", chronic trauma of the inner emotional world of the gymnast with enormous psychological costs (the feeling of fear and unbearable psychological pressure reaching the limits of coercion). The coach - athlete relationship should be governed by trust and positive motivation. Under the present conditions, it is estimated that only through the guidance of a responsible coach can the number of athletes who are in danger of developing eating disorders be drastically reduced. For the early identification of predisposing risk factors of the female athlete triad, a procedure is necessary to inform and educate coaches, parents and athletes. The procedure should include intervention programs and aim at improving the dietary attitudes, early identifying predisposing risk factors of the female athlete triad, and enhancing physical self-perception and self-image of the athletes. Furthermore, it would be particularly useful to educate athletes in methods of concentration, in managing pre-competition stress and in effectively controlling anxiety (Byrne & Mclean, 2002; Duffy, 2008; Kosmidou, 2014).

5. For injury prevention, the authors suggest reducing the frequency and duration of the many hours of training of elite athletes, which are often twice a day, morning and afternoon. Such a proposition will surely provoke fruitful

discussions/debates in modern coaching. To avoid injuries and monotony, a larger variety of apparatus training could be adopted during each session. Undoubtedly, the strict coaching structures that characterise AG and RG with early specialisation, long hours of daily training and few official competitions, need redesigning.

6. In order for female athletes to continue their athletic career in safety, it is an absolute priority (Bratland-Sanda & Sundgot-Borgen, 2013; De Souza et al., 2014; Sundgot-Borgen et al., 2013; Wilde, 2013):

- to regulate their menstrual cycle
- to ensure the qualitative and quantitative adequacy of their diet
- to "reconcile" themselves with their body and to indirectly enhance their self-esteem
- to set an "acceptable" body mass limit for each gymnast, that is based on all relevant scientific criteria.

Targeted directions for nutritional support of elite athletes of AG and RG

1. Nutritional assessment by a qualified sports dietitian throughout the yearly competitive season with frequent detailed re-examination (as appropriate for each gymnast) is necessary.

2. Particular emphasis should be given to the gymnast's adequate daily nutritional balance (qualitative and quantitative) and nutritional sufficiency, in the following order (Academy of Nutrition and Dietetics, 2016; Desbrow et al., 2014; Meyer & Manore, 2011; Driskell & Wolinsky, 2011; Sundgot-Borgen & Garthe, 2011):

- Energy (not < 1800 kcal/day and \geq 40 kcal/kg BW or > 45 kcal/kg lean mass) with emphasis on carbohydrates (\geq 5 gr/kg BW/day: dry and/or cooked; simple sugars complex carbohydrates) and on the time of the energy intake to ensure glycogen reserves
- Fat (not < 30% of total energy intake): Hormonal function, fat-soluble vitamins (A, D, E)

- Calcium (not < 1300 mg/day): Increased need of calcium due to the accelerated pubertal development, especially in female athletes with menstrual dysfunction
- Vitamin D (not < 15 mg/day): Skeletal health, anti-inflammatory effect, calcium absorption
- Iron (20 mg/day): Haemoglobin synthesis, oxygen transfer system, increased developmental needs, developing muscular system - protein synthesis, preventing iron deficiency
- Zinc (10 mg/day): Strengthening the immune system and supporting adolescent development.

We believed that, especially during the critical developmental ages, adding 2-3 inter-mediate meals (snacks) is critical. Furthermore, reduced daily calcium intake is considered an important predisposing factor to low bone accretion, which in turn is associated with an increased likelihood of stress fractures.

3. Adequate hydration, frequent consumption of fluids and electrolytes is required. Due to greater body surface area (per kg of body mass), children are more prone to exercise-induced heat strain and thermal disturbances (faster heat absorption, lower sweating rate) (Desbrow et al., 2014; Meyer, Volterman, Timmons, & Wilk, 2012). In any case, losses \geq 2% of body mass should be avoided during training or competitions.

4. A strategy of favourable energy support and fluid replacement, during and after training, through specially designed snacks with high glycaemic index is advisable. With customary training sessions being > 3 h, energy coverage/support with carbohydrates and electrolytes at the right time and in sufficient quantities is required during the long hours of training. The basic rule is \geq 30 gr of carbohydrates per hour (or 0.5 gr carbohydrate + 0.2 gr of protein /kg BM /h). This guideline:

- is the most critical parameter for the promotion and acceleration of the recovery process [faster healing of

minor injuries, rehabilitation of injured cells/tissues, protection of the immune system] from muscle strain/fatigue from training (Academy of Nutrition and Dietetics, 2016; Desbrow et al., 2014; Meyer & Manore, 2011),

- Is individualised as appropriate in accordance with the specific needs, objectives, coaching priorities and level of the athlete (Academy of Nutrition and Dietetics, 2016; Desbrow et al., 2014; Meyer & Manore, 2011).

For the same reason, and in order for the daily rate of protein synthesis to be maintained at a satisfactory level and for aminoacids to be sufficiently available, the correct distribution of the daily protein meal (e.g. 4 x 20 gr) is necessary to cover the required daily amount ($\geq 1,5$ gr of protein/kg). The "key" is the planning of portions at specific times, in order to achieve optimal protein availability and better use by the body.

5. Administering creatine is a matter open to discussion in the scientific community. Creatine has a significant contribution to the anaerobic muscle metabolism and it is used as an ergogenic aid mainly in anaerobic high intensity sports. The administration of creatine appears to limit the exercise-induced muscle damage both through the reduction of delayed muscle pain and fatigue, and by reducing the levels of creatine kinase and lactate dehydrogenase in the plasma (Bassit et al., 2010). For endurance sports, there is disagreement on its effect (increasing body mass) and especially for ages up to 18 years. In general, though, for ages <18 years, creatine supplementation safety has not been established (Cooper et al., 2012). To date there are no recorded systematic creatine supplementation data in competitive gymnastics probably because in sports such as AG and RG where numerous rest periods are observed (non-practicing periods) and actual practice time per session does not exceed 60-80 minutes and is not considered high volume, the amount of

creatine needed by the body is obtained through the gymnast's daily diet (fish-meat).

6. A general evaluation of the health risks, particularly where early warning signs are available (first detection level) including:

- Loss of large amounts of blood (heavy bleeding) during menstruation
- Longer/sparse menstrual cycles (oligomenorrhea) or fluctuations in the frequency of menses (in particular the absence of 3 consecutive cycles)
 - Primary or secondary amenorrhea
 - Restricted eating behaviours
 - Frequent daily weighing
 - Early, unexplained fatigue
 - Systematic and persistent refusal of food and liquid intake

Each coach should also be able to promptly recognise these predisposing risk factors.

7. A monthly assessment of body fat and a weekly assessment of body mass is recommended; various field methods have been proposed such as anthropometry (skinfolds), anthropometry (skinfolds equations) (Ackland et al., 2012). Furthermore, given the different pace of biological maturation and physical development of each gymnast, the assessment of body fat and body mass should be individualized. There is no default value but an approximate optimum value, where the personal history coincides and is co-evaluated with the athletic performance and the promotion / maintenance of health. In any case, our goal is a fixed body mass between $- 1 < BM < + 1$ kg (range up to $\pm 2\%$) during the annual competitive season, since the daily weighing usually fluctuates ± 1 kg (Sundgot-Borgen & Garthe, 2011).

8. It is sad, but typical of the attitudes and intentions of the coaches, that individual weighing of athletes has been established as part of the daily training. We recommend that coaches reconsider and avoid this practice. Coaches should be aware that the scale is a "tough opponent" in

the management of specific cases of athletes who are prone to developing eating disorders and that body composition is not always the ultimate competitive advantage since: a) athletic performance is shaped by a set of different parameters, b) there is great variation in body fat percentages between successful high-level athletes (Turocy et al., 2011). Therefore, any misconception and futile expectation of the "ideal" body mass (or ideal body fat), should be discouraged (or even eliminated) as they are not viable scientific terms.

9. In "aesthetic" sports, the role of the coach is decisive during these sensitive developmental ages, in terms of informing athletes of the immediate and long-term negative consequences: a) of reduced energy intake (malnutrition), b) of menstrual disorders and c) of the loss of valuable bone mass. Undoubtedly, total cooperation between coaches and parents (information, supervision, monitoring, guidance, compliance) is required (Holli & Beto, 2014).

CONCLUSIONS

Pre-adolescent and adolescent gymnasts, and especially artistic gymnasts (AG) and rhythmic gymnasts (RG), belong to a high risk group for severe deficiency in /lack of basic nutrients, especially calcium, iron, folic acid, vitamin D and zinc. Basic purpose of this study is to provide targeted nutritional support directions to elite athletes of AG and RG with priority and emphasis on strengthening the immune system, nutritional strategy for direct energy recovery and the synchronization of the time-divided daily nutritional intake throughout the year's training season. For chronic forms of reduced energy intake it should be emphasized that it is detrimental to athletic performance and is considered a forerunner of negative development with serious future health consequences: weaker immune system, critical nutrient deficiencies, dehydration, chronic fatigue, menstrual and hormonal disorders, decreased bone density, increased injury

susceptibility and increased risk of developing permanent eating disorders.

REFERENCES

Academy of Nutrition and Dietetics, Dietitians of Canada, and the American College of Sports Medicine Position statement. (2016). Nutrition and Athletic Performance. *Journal of Academic Nutrition and Diet*, 116, 501-528.

Ackland, T. R., Lohman, T.G., Sundgot-Borgen, J., Maughan, R.J., Meyer, N.L., Stewart, A.D., & Muller, W. (2012). Current status of body composition assessment in sport: review and position statement on behalf of the ad hoc Research Working Group on Body Composition Health and Performance, under the auspices of the IOC Medical Commission. *Sports Medicine*, 42, 227-249.

Ackerman, K., & Madhusmita, M. (2011). Bone health and the female athlete triad in adolescent athletes. *Physician and Sports Medicine*, 39, 131-141.

Bahner C. (2009). The effectiveness of the Female Athlete Triad components in identifying collegiate athletes at potential risk of long-term health consequences. *Master's Thesis*. Oklahoma State University. Stillwater, OK.

Barrack, M., Gibbs, J.C., De Souza, M.J., Williams, N.I., Rauh, M.J., & Nattiv, A. (2014). Higher incidence of bone stress injuries with increasing female athlete triad-related risk factors. *American Journal of Sport Medicine*, 42, 949-958.

Bassit, R.A., Pinheiro, C.H., Vitzel, K.F., Sproesser, A.J., Silveira, L.R., & Curi R. (2010). Effect of short-term creatine supplementation on markers of skeletal muscle damage after strenuous contractile activity. *European Journal of Applied Physiology*, 108, 945-955.

Beals, K. (2004). *Disordered Eating among Athletes – A Comprehensive Guide for Health Professionals*. Champaign, IL: Human Kinetics Publications.

Benardot, D. (2014). Gymnastics. In: R. Maughan (Ed.) *Sports Nutrition; The Encyclopedia of Sports Medicine* (pp.596–

606). (Vol. VIX). London: IOC Medical Commission Publication; John Wiley and Sons Ltd.

Benson, J.E., Engelbert-Fenton, K.A., & Eisenman, P.A. (1996). Nutritional aspects of amenorrhea in the female athlete triad. *International Journal of Sport Nutrition*, 6, 134-145.

Black, A. (2000). The sensitivity and specificity of the Goldberg cut-off for EI: BMR for identifying diet reports of poor validity. *European Journal of Clinical Nutrition*, 54, 395-404.

Black, A. (2001). Dietary assessment for sports dietetics. *Nutrition Bulletin*, 26(1): 29-42.

Bonci, C.M., Bonci, L.J., Granger, L.R., Johnsonm C,L,, Malinam R,M,, Milnem L,W., Ryanm, R.R., & Vanderbuntm E.M. (2008). National Athletic Trainers' Association Position Statement: Preventing, detecting, and managing disordered eating in athletes. *Journal of Athletic Training*, 43, 80-108.

Bratland-Sanda, S., & Sundgot-Borgen, J. (2013). Eating disorders in athletes: Overview of prevalence, risk factors and recommendations for prevention and treatment. *European Journal of Sport Science*, 13, 499-508.

Burke, L. (2015). Dietary assessment methods for the athlete: Pros and cons of different methods. *Sports Science Exchange*, 28(150), 1-6.

Burt, L., Greene, D.A., Ducher, G., & Naughton, G.A. (2013). Skeletal adaptations associated with pre-pubertal gymnastics participation as determined by DXA and pQCT: A systematic review and meta-analysis. *Journal of Sport Science and Medicine in Sport*, 16, 231-239.

Byrne, S., & Mclean, N. (2002). Elite athletes: Effects of the pressure to be thin. *Journal of Sport Science and Medicine in Sport*, 5, 80-94.

Caine, D., Russell, K., & Lim, L. (Eds) (2013). *Gymnastics. Handbook of Sports Medicine and Science*. London: IOC Medical Commission Publication. John Wiley and Sons Ltd.

Crenshaw, G. (2009). Energy intakes of Female Collegiate Athletes. *Master Thesis*, Oklahoma State University. Stillwater, OK.

Cooper, R., Naclerio, F., Allgrove, J., & Jimenez, A. (2012). Creatine supplementation with specific view to exercise/sports performance: an update. *Journal of the International Society of Sports Nutrition*, 9, 33. <http://www.jissn.com/content/9/1/33>

Cupisti, A., D'Alessandro, C., Gastrogiovanni, S., Barale, A., & Morelli, E. (2000). Nutrition survey in elite rhythmic gymnasts. *Journal of Sport Medicine and Physical Fitness*, 40, 350-355.

D'Alessandro, C., Morelli, E., Evangelisti, I., Galetta, F., & Franzoni, F. (2007). Profiling the diet and body composition of subelite adolescent rhythmic gymnasts. *Pediatric Exercise Science*, 19, 215-227.

Dallas, G., Simatos, J., & Dallas, C. (2016). Nutritional status and dietary assessment of elite female artistic and rhythmic gymnastics – a case study. *Science of Gymnastics Journal*, 3(8), 255-269.

De Bruin, A., Oudejans, R.R.D., & Bakker, F. (2007). Dieting and body image in aesthetic sports: A comparison of Dutch female gymnasts and non-aesthetic sport participants. *Psychology of Sport and Exercise*, 8, 507-520.

Desbrow, B., McCormack, J., Burke, L.M., Cox, G.R., Fallon, K., Hislop, M., Logan, R., Marino, N., Sawyer, S.M., Shaw, G., Star, A., Vidgen, H., & Leveritt, M. (2014). Sports Dietitians Australia Position Statement: Sports Nutrition for the Adolescent Athlete. *International Journal of Sport Nutrition and Exercise Metabolism*, 24, 570-584.

De Souza, M., Nattiv, A., Joy, E., Misra, M., Williams, N.I., Mallinson, R.J., Gibbs, J.C., Olmsted, M., Goolsby, M., & Matheson, G. (2014). Female athlete triad coalition consensus statement on treatment and return to play. *British Journal of Sport Medicine*, 48, 289-308.

De Souza M., & Williams N. (2004). Physiological aspects and clinical sequelae

of energy deficiency and hypoestrogenism in exercising women. *Human Reproduction Update*, 10, 433-448.

Deutz, R.C., Benardot, D., Martin, D.E., & Cody, M.M. (2000). Relationship between energy deficits and body composition in elite female gymnasts and runners. *Medicine and Science in Sport and Exercise*, 32, 659-668.

Di Cagno, A., Marchetti, M., Battaglia, C., Giombini, A., Calcagno, G., Fiorilli, G., Piazza, M., Pigozzi, F., Borriore, P. (2012). Is menstrual delay a serious problem for elite rhythmic gymnasts? *Journal of Sport Medicine and Physical Fitness*, 52, 647-653.

Driskell, J., & Wolinsky I. (2011). *Nutritional Assessment of Athletes*. Boca Raton, FL: CRC Press.

Ducher, G., Turner, A.I., Kukuljan, S., Pantano, K.J., Carlson, J.L., Williams, N.I., & De Souza, M.J. Obstacles in the optimization of bone health outcomes in the female athlete triad. *Sports Medicine*, 41, 587-607.

Dueck, C.A., Manore, M.M., & Matt, K.S. (1996). Role of energy balance in athletic menstrual dysfunction. *International Journal of Sport Nutrition*, 6, 165-190.

Duffy, A. (2008). Perfectionism, perfectionistic Self-presentation, body comparisons and disordered eating in women's Artistic Gymnastics. *Master Thesis*, Auburn University. Auburn, AL.

Ferrand, C., Champely, S., & Filaire, E. (2009). The role of body-esteem in predicting disordered eating symptoms: A comparison of French aesthetic athletes and non-athletic females. *Psychology of Sport and Exercise*, 10, 373-380.

Filaire, E., Colombier, J.P., Beque, R.J., & Lac, G. (2003). Effects of 16 weeks of training prior to a major competition on hormonal and biochemical parameters in young elite gymnasts. *Journal of Pediatric Endocrinology and Metabolism*, 16, 741-750.

Francisco, R., Alarcao, M., & Narciso, I. (2012). Aesthetic sports as high-risk contexts for eating disorders – Young elite dancers and gymnasts perspectives. *The*

Spanish Journal of Psychology, 15, 265-274.

Fuqua, J., & Rogol, A. (2013). Endocrinology. In: Caine D., Russell K., Lim L. *Gymnastics. Handbook of Sports Medicine and Science*. IOC Medical Commission Publication. London: John Wiley & Sons Ltd. (pp. 28-39).

Georgopoulos, N., Markou, K.B., Theodoropoulou, A., Benardot, D., Leglise, M., & Vagenakis, A.G. (2002). Growth retardation in artistic compared with rhythmic elite female Gymnasts. *Journal of Clinical Endocrinology and Metabolism*, 87, 3169-3173.

Gibbs, J.C., Williams, N.I., Mallinson, R.J., Reed, J.L., Rickard, A.D., & De Souza, M.J. (2013). Effect of high dietary restraint on energy availability and menstrual status. *Medicine and Science in Sport and Exercise*, 45, 1790-1797.

Gibson, R. (2005). *Principles of Nutritional Assessment*. New York, Oxford University Press.

Goldberg, G., & Black, A. (1998). Assessment of the validity of reported energy intakes - Review and recent developments. *Scandinavian Journal of Nutrition*, 142, 6-9.

Greene, D., & Naughton, G. (2006). Adaptive skeletal responses to mechanical loading during adolescence. *Sports Medicine*, 36, 723-732.

Heaney, S., O'Connor, H., Gifford, J., & Naughton, G. (2010). Comparison of strategies for assessing nutritional adequacy in elite female athletes' dietary intake. *International Journal of Sport Nutrition and Exercise Metabolism*, 20, 245-256.

Hill, R., & Davies, P. (2001). The validity of self-reported energy intake as determined using the doubly labeled water technique. *British Journal of Nutrition*, 85, 415-430.

Hoch, A., Goossen, K., & Kretschmer, T. (2008). Nutritional requirements of the child and teenage athlete. *Physical Medicine and Rehabilitation Clinics of North America*, 19, 373-398.

Holli, B., & Beto, J. (2014). *Nutrition Counseling and Education Skills for*

Dietetics Professionals. Baltimore, MD: Lippincott Williams & Wilkins.

Jonnalagadda, S.S., Benardot, D., & Dill, M.N. (2000). Assessment of under-reporting of energy intake by elite female gymnasts. *International Journal of Sport Nutrition and Exercise Metabolism*, 10(3), 315-325.

Jonnalagadda, S.S., Bernadot, D., & Nelson, M. (1998). Energy and nutrient intakes of the United States national women's artistic gymnastics team. *International Journal of Sports Nutrition*, 8, 331-344.

Kerr, G., Berman, E., & De Souza, M.J. (2006). Disordered eating in women's Gymnastics: Perspectives of athletes, coaches, parents, and judges. *Journal of Applied Sport Psychology*, 18, 28-43.

Klentrou P., & Plyley M. (2003). Onset of puberty, menstrual frequency, and body fat in elite Rhythmic gymnasts compared with normal controls. *British Journal of Sport Medicine*, 37, 490-494.

Kolt, G., & Kirkby, R. (1999). Epidemiology of injury in elite and subelite female gymnasts: A comparison of retrospective and prospective findings. *British Journal of Sports Medicine*, 33, 312-31.

Kosmidou E. (2014). Physical self-perception, body image and eating attitudes of Rhythmic gymnasts: Development and evaluation of the intervention program. *Doctoral dissertation theses*. Aristotelio University of Thessaloniki (in Greece).

Lebenstedt, M., Platte, P., & Pirke, K.M. (1999). Reduced resting metabolic rate in athletes with menstrual disorders. *Medicine and Science in Sport and Exercise*, 31, 1250-1256.

Lovell, G. (2008). Vitamin D status of females in an elite gymnastics program. *Clinical Journal of Sport Medicine*, 18(2), 159-161.

Maffulli, N., Longo, U.G., Spiezia, F., & Denaro, V. (2011). Aetiology and prevention of injuries in elite young athletes. In: *Armstrong N., McManus A. (Eds) The Elite Young Athlete*. Med.

Sport Science Series (Vol. 56). Basel (Switzerland): Karger Publ. (pp. 187-200).

Maïmoun, L., Coste, O., Georgopoulos, N.A., Roupas, N.D., Mahadeam, K.K., Tsouka, A, Mura, T., Philibert, P., Gaspari, L., Mariano-Goulard, D., Leglise, M., & Sultan, C. (2013). Despite a high prevalence of menstrual disorders, bone health is improved at a weight-bearing bone site in world-class female Rhythmic Gymnasts. *Journal of Clinical Endocrinology and Metabolism*, 98, 4961-4969.

Maïmoun, L., Georgopoulos, N.A., & Sultan, C. (2014). Endocrine disorders in adolescent and young female athletes: Impact on growth, menstrual cycles, and bone mass acquisition. *Journal of Clinical Endocrinology and Metabolism*, 99, 4037-4050.

Malina, R.M., Baxter-Jones, A.D.M., Armsrton, N., Beunen, G.P., Caine, D., Daly, R.M., Lewis, R.D., Rogol, A.D., & Russell, K. (2013). Role of intensive training in the growth and maturation of Artistic Gymnasts. *Sports Medicine*, 43, 783-302.

Mallinson, R., & De Souza, M. (2014). Current perspectives on the etiology and manifestation of the "silent" component of the female athlete triad. *International Journal of Womens Health*, 6, 451-446.

Markou, K., Mylonas, P., Theodoropoulou, A., Kontogiannis, A., Leglise, M., Vagenakis, A.G., & Georgopoulos, N.A. (2001). The influence of intensive physical exercise on bone acquisition in adolescent elite female and male artistic Gymnasts. *Journal of Clinical Endocrinology and Metabolism*, 89, 4383-4387.

McManus, A., & Armstrong, N. (2011). Physiology of elite young female athletes. In: *McManus A., Armstrong N. (Eds)*. The Elite Young Athlete (Vol. 56). Basel: Karger (pp. 23-46).

McMurray, R. (2011). Laboratory methods for determining energy expenditure of Athletes. In: *Driskell J., Wolinsky I. (Eds)*. Nutritional Assessment of Athletes. Boca Raton, FL: CRC Press (pp. 151-181).

Meyer, N., and Manore, M. (2011). Evaluation of nutrient adequacy of Athletes' diets. In: J. Driskell, I. Wolinsky (Eds.). *Nutritional Assessment of Athletes*. (pp.51-70). Boca Raton, FL: CRC Press.

Meyer, F., Volterman, K.A., Timmons, B., & Wilk, B. (2012). Fluid balance and dehydration in the young athlete: Assessment considerations and effects on health and performance. *American Journal of Lifestyle Medicine*, 6, 489-501.

Michopoulou, E., Avloniti, A., Kambas, A., Leontsini, D., Michalopoulou, M., Tournis, S., & Fatouros, I.G. (2011). Elite premenarcheal Rhythmic gymnasts demonstrate energy and dietary intake deficiencies during periods of intense training. *Pediatric Exercise Science*, 23, 560-572.

Nordin, S.M., Harris, G., & Cumming, J. (2003). Disturbed eating in young, competitive Gymnasts: Differences between three gymnastics disciplines. *European Journal of Sport Science*, 3, 1-14.

Pavlou, K.N. (1992). *Nutrition - Physiology and Sports* (in Greek). Athens, Self-published.

Rottstein, L. (2013). The effect of strenuous exercise on growth and puberty of highly competitive athletes. *Doctoral Disseretaiton*. Department of Medicine, University of Patras.

Roupas, N., & Georgopoulos, N. (2011). Menstrual function in sports. *Hormones*, 10, 104-112.

Sands, W., Caine, D., & Borms J. (Eds) (2003). *Scientific Aspects of Women's Gymnastics*. Medicine Sport Science, (Vol. 45). Basel: Karger Publ.

Silva, M., & Paiva, T. (2015). Low energy availability and low body fat of female gymnasts before an international competition. *European Journal of Sport Science*, 15, 591-599.

Smith, A. (2000). Gymnastics. In: *Drinkwater B. (Ed) Women in Sport*. The Encyclopedia of Sports Medicine (Vol. VIII). Oxford: Blackwell Science (pp.494-509).

Soric, M., Misiqoi-Durakovic, M., & Pedisis, Z. (2008). Dietary intake and body

composition of Prepubescent female aesthetic athletes. *International Journal of Sport Nutrition and Exercise Metabolism*, 18, 343-354.

Steinmuller, P.L., Kruskall, L.J., Karpinski, C.A., Manore, M.M., Macedonio, M.A., & Meyer, N.L. (2014). Academy of Nutrition and Dietetics: Revised 2014 Standards of Practice and Standards of Professional Performance for Registered Dietitian Nutritionists (Competent, Proficient, and Expert) in Sports Nutrition and Dietetics. *Journal of Academic Nutrition and Diet*, 114(4), 631-641.

Sundgot-Borgen, J., & Garthe, I. (2011). Elite athletes in aesthetic and Olympic weight-class sports and the challenge of body weight and body composition. *Journal of Sport Science*, 29 (S1), 114.

Sundgot-Borgen, J., Meyer, N.L., Lohman, T.G., Ackland, T.R., Maughan, R.J., Stewart, A.D., & Muller, W. (2013). How to minimize the health risks to athletes who compete in weight sensitive sports: Review and position statement of the research working group on body composition, health and performance (IOC Medical Commission). *British Journal of Sport Medicine*, 47, 1012-1022.

Thompson, J. (1998). Energy balance in young athletes. *International Journal of Sport Nutrition and Exercise Metabolism*, 8, 160-174.

Tofler, I.R., Stryer, B.K., Micheli, L.J., & Herman, L.R. (1996). Physical and emotional problems of elite female gymnasts. *New England Journal of Medicine*, 335, 281-283.

Torstveit, M.K., Rosenvinque, J.H., & Sundgot-Borgen, J. (2008). Prevalence of eating disorders and the predictive power of risk models in female elite athletes: a controlled study. *Scandinavian Journal of Medicine and Science in Sport*, 18, 108-118.

Tournis, S., Michopoulou, E., Fatouros, I.G., Paspati, I., Michalopoulou, M., Raptou, P., Leontsini, D., Avloniti, A., Krekoukia, M., Zouvelou, V., Galanos, A., Aggelousis, N., Kambas, A., Douroudos, I.,

Lyritis, G.P., Taxildaris, K., & Pappaioannou, N. (2010). Effect of Rhythmic Gymnastics on volumetric bone mineral density and bone geometry in premenarcheal female athletes and controls. *Journal of Clinical Endocrinology and Metabolism*, *95*, 2755-2762.

Trexler, E.T., Smith-Ryan, A.E., & Norton, L.E. (2014). Metabolic adaptation to weight loss: Implications for the athlete. *Journal of the International Society of Sports Nutrition*, *11*, 7.

Turocy, P.S., DePalma, B.F., Horswill, C.A., Laquale, K.M., Martin, T.J., Perry, A.C., Somova, M.J., & Utter, A.C. (2011). National Athletic Trainers' Association Position Statement: Safe weight loss and maintenance practices in sport and exercise. *Journal of Athletic Training*, *46*, 322-336.

Vicente-Rodriguez, G., Dorado, C., Ara, I., Perez-Gomez, J., Olmedillas, H., Delgado-Guerra, S., & Calbet, J.A. (2007). Artistic vs rhythmic gymnastics: Effects on bone and muscle mass in young girls. *International Journal of Sports Medicine*, *28*, 386-393.

Warren, M., & Constantini, N. (Eds) (2000). *Sports Endocrinology*. N. Jersey: Humana press.

Warren, M., & Perlroth, N. (2011). The effects of intense exercise on the female reproductive system. *Journal of Endocrinology*, *170*, 3-11.

Weimann, E. (2002). Gender-related differences in elite gymnasts: the female athlete triad. *Journal of Applied Physiology*, *92*, 2146-2152.

Weimann, E., Witzel, C., Schwiderqall, S., & Bohles, H.J. (2000). Peripubertal perturbations in elite gymnasts caused by sport specific training regimes and inadequate nutritional intake. *International Journal of Sport Medicine*, *21*, 210-215.

Wilde, H. (2013). Assessment of risk factors for the Female Athlete Triad in female collegiate gymnasts. *Master's Thesis*, University of Wisconsin-Stout. Menomonie, WI.

Williams, N.I., Helmreich, D.L., Parfitt, D.B., Caston-Balderrama, A., & Cameron, J.L. (2001). Evidence for a causal

role of low energy availability in the induction of menstrual cycle disturbances during strenuous exercise training. *Journal of Clinical Endocrinology and Metabolism*, *86*, 5184-5193.13.

Zach, K. (2011). Advances in management of the female athlete triad and eating disorders. *Clinics in Sports Medicine*, *30*, 551-57.

Zetaruk, M. (2000). The young gymnast. *Clinics in Sports Medicine*, *19*, 757-780.

Corresponding author:

George Dallas
School of Physical Education and Sport
Science, National and Kapodistrian
University
phone: 0030 210 66 43 704
fax: 0030 693 65 92 665
e-mail: gdallas@phed.uoa.gr

IT WAS WORTH IT– I WOULD DO IT AGAIN!: PHENOMENOLOGICAL PERSPECTIVES ON LIFE IN THE ELITE WOMEN’S ARTISTIC GYMNASTICS

Joca Zurc

Faculty of Health Sciences Novo mesto, Slovenia

Original article

Abstract

The Olympic Movement emphasizes the importance of protecting athletes’ health and eliminating all possible risks. Many international documents provide similar recommendations, especially the United Nations Convention on the Rights of the Child. Yet, elite sport continues to represent a risk, especially in athletes who compete as pre-adolescent children. Women’s artistic gymnastics is an Olympic sport where the age of competitors has been the lowest in the last 40 years. The purpose of our empirical research was to investigate the opinions of female gymnasts on their sports careers and top achievements in artistic gymnastics. In addition, we were interested in the opinions of coaches on the appropriate age for a child to start training and competing in women’s artistic gymnastics. The results of the qualitative research conducted on a sample of 26 active and 11 retired Slovenian female gymnasts and four of their coaches revealed that the respondents would take the same career path again, despite the specific lifestyle they had to lead, many sacrifices they had to make, adverse events they faced, and the consequences on their physical and mental health. The coaches agreed that the age of a child determines their gymnastics career, but their opinions differed over whether the age limit for entering senior competitions should be raised from 16 years to 18 years. The study also provides recommendations for gymnastics clubs on finding a more successful approach towards working with young, talented athletes.

Keywords: elite child athlete, ethics, wellbeing, human rights, qualitative thematic analysis.

INTRODUCTION

Pursuant to its mission, the Olympic Movement encourages measures which ensure that sport is practiced without harmful consequences for the athletes. Therefore, health protection of athletes must be encouraged and possible risks of injury or psychological harm avoided (Olympic Movement Medical Code, 2009). Similar guidelines are also found in international documents on the protection of human rights, especially the United Nations Convention on the Rights of the Child—the most widely and rapidly ratified international human rights treaty in history (Ensalaco, 2005; Council of the European

Union, 2009; Jager Agius, 2014; Šelih, 2014). Two basic principles are identified in the convention: ‘the best interests of the child’ and ‘considering the developmental abilities of the child’, both emphasizing that a child’s best interest should be the leading principle in all activities and treatment involving children (Convention on the Rights of the Child, 1989; Šelih, 2014).

However, Paulo (2005) points out that competitive sport often does not conform to international norms and standards regarding children’s rights. On the contrary, children’s rights in elite sport remain a taboo, both in terms of protecting basic human rights and

the rights of athletes. As a consequence, this important issue continues to remain under-researched.

A specific risky environment in elite sport has been brought to public attention— inclusion in intensive training and learning very difficult elements early on in childhood among female artistic gymnasts. Women's artistic gymnastics is one of the most attractive Olympic disciplines. In addition to fascinating acrobatics, its appeal is enhanced by the fact that it belongs to a group of sports where it is not enough to only perform the elements higher, faster and stronger, but the manner in which the elements are performed is extremely important as well. Moreover, women's artistic gymnastics is an interesting research field because athletes tend to start training at a very early age. Elite female gymnasts throughout the world start training between the ages of five and seven, and are included in professional training of the elite level of gymnastics by the time they turn 10 (Tofler, Katz Stryer, Micheli, & Herman, 1996). Intensive training subjects female gymnasts to extreme strain in the pre-adolescence period, placing them at a higher risk of both physical and psychological developmental deficits (Caine, Russell, & Lim, 2013). Data reported by British Gymnastics revealed an above-average number of child abuse cases in gymnasts compared to the general population, with the major risk factor being the age of female gymnasts (Collins, 2012). Moreover, Farstad (2006) found in her research that, despite the fact that injuries can occur in any sport, they are especially prevalent among female gymnasts due to their young age. The author wonders whether committing a child to six hours of training a day for six days a week does not constitute a full-time employment relation, from which all underage children should be protected.

Intensive training programmes from early childhood on can lead to different kinds of abuse in child athletes (Pinheiro, Pimenta, Resende, & Malcolm, 2014). Producing world and Olympic champions in women's gymnastics during the period of

pre-adolescence has several documented consequences, including negative weight control methods, eating disorders, severe physical injuries, corporal punishment, training/competing with injuries, psychological abuse, lack of time for resting and leisure activities, adverse effects on health and development, decreased school performance, absence from home, lack of social contact with non-athletes, sexual abuse, and substance abuse (Sundgot-Borgen, & Torstveit, 2004; Farstad, 2006; Lassiter, & Watt, 2007; Sahlstrom, & Jeglic, 2008; Timpka, Finch, Goulet, Noakes, & Yammine, 2008; Gannon, & Cortoni, 2010; Zurc, Rhind, & Lang, 2014; Pinheiro et al., 2014). In fact, the long-reaching consequences of physical and psychological abuse in young athletes can be detected even after the conclusion of their professional careers, but most athletes regard them as a normal, acceptable part of elite sport culture, minimizing or even denying any negative effects on their lives after the conclusion of their professional sports careers (Pinheiro et al., 2014; Papaefstathiou, Rhind, & Brackenridge, 2012; Stirling, & Kerr, 2012). Based on discursive and rhetorical resources analysis on a sample of 25 articles from the Swedish newspaper *Dagens Nyheter*, Stier and Blomberg (2015) established the authenticity of female gymnasts' statements reinforcing and giving legitimation to unhealthy behaviour, wrongdoings, and leadership culture in gymnastics. The analysis revealed a downsizing of the gymnast's voice, power asymmetry between coach and gymnast, and denial of the issue or any wrongdoings from the gymnastics clubs, National Gymnastics Federation, and the National Olympic Committee. In doing so, the current world of gymnastics violates the United Nations Convention on the Rights of the Child and highlights the need for developing new models which would challenge the traditional approach on how to manage elite-level gymnastics training.

Based on all this evidence, the voices of advocates for the importance of protecting and ensuring the wellbeing and

welfare of children in sports have been raised in recent years. Their criticism is directed at the negative competitive atmosphere in adolescent sports and the acceptability of violence in youth sports, and they have expressed their concerns about the risk of abuse in elite child athletes (Gretchen, 2010; Brackenridge, 2010). An increased concern for ensuring the safety of child athletes has also encouraged new research in this field (Papaefstathiou et al., 2012).

Keeping this evidence in mind, the aim of our empirical research was to examine the opinions of female gymnasts on their career of producing top-level achievements in elite artistic gymnastics and to determine the factors that can influence it. In addition, we were interested in coaches' opinions on the right age for female gymnasts to start training and competing in artistic gymnastics.

METHODS

An phenomenological research design was employed, with in-depth retrospective semi-structured interviews. We examined the personal experiences with elite sport of active and retired Slovenian elite female gymnasts, and perspectives on elite gymnastics of their coaches. The phenomenological approach is dedicated to studying the life experiences of the same phenomenon of reality from the views of different individuals. The different descriptions of life experiences contribute to their understanding and interpretation (Creswell, 2014). The aim is to understand the constructs of individuals, with which they experience their daily reality (Ritchie, & Lewis, 2006).

The research included 37 Slovenian elite female gymnasts, of which 26 were current cadet, junior or senior members of the Slovenian national gymnastics team, and 11 gymnasts who were members of the junior or senior national gymnastic teams of Yugoslavia or Slovenia in the late 1980s and early 1990s. Snowball sampling—a

sampling method enabling access to dispersed, small and specific population groups—was employed to obtain the sample of female gymnasts (Ritchie, & Lewis, 2006). In addition to the gymnasts, the research also included four of their coaches.

Gymnast respondents started training, on average, at the age of six. A decrease in the starting age was noted for gymnasts who started training after 1995. The mean age of active gymnast respondents at the time of the interview was 14 years (the youngest active female gymnast was 10 years old and the oldest was 22 years old), and they had been training gymnastics for a mean length of 8.0 years. Their senior peers who started training gymnastics between 1969 and 1997 trained for an average of 11.77 years. In recent years, there has been a trend towards prolonging the period of training and competing in gymnastics, which was shortest in the 1980s, when it lasted for an average of 10 years. At the time of the interview, retired gymnasts had not been training for an average of 18 years.

All the coach respondents coached both active and retired gymnast respondents. They started coaching when they were 16 to 30 years old, with an average of 21 years. At the time of the interview, they had been coaching for an average of 28 years and started coaching in 1970 or later.

A semi-structured interview was used to collect data. Following a pilot study, which helped us improve the wording of questions, the sequence of questions, and to add sub-questions to different topics, the final survey instrument was developed. This instrument was used to collect empirical research data on the entire sample of female gymnasts and their coaches (Zurc, 2015). The article presents the results for the following variables included in the interview:

- demographic data (status: active/retired, age at the time of interview, age at the beginning and end of career or coaching, total period of training or coaching),
- opinions of female gymnasts on their career of producing top-level

achievements in elite artistic gymnastics and factors that influence it,

- lifestyle of a female gymnast between the ages of 9 and 14,
- attitude towards career in gymnastics—would you do it again?,
- opinions of coaches on the right age for female gymnasts to start training and competing in artistic gymnastics in order to produce top-level achievements.

Interviews with the gymnasts were conducted from December 12, 2012, to February 18, 2013. The time and place of the interview were agreed on according to the respondent's preferences. Most interviews were conducted in the afternoon, between 5 and 9 p.m., but there were also some conducted on Saturday morning, between 8 and 12 p.m. Interviews with active gymnasts and their coaches were conducted at the Zelena Jama Gymnastics Club and the Gib Šiška Sports Club in Ljubljana, where most of the junior and senior national gymnastics team members train. Half of the interviews (n=6) with retired elite gymnasts were also conducted at gymnastics clubs: three were conducted at their homes, one in an office, and one in a café. All 37 interviews were conducted by one researcher, author of this article, and on an individual manner. The interviewer and the interviewee were in private room alone during the conversation. The average duration of an interview with a female gymnast was 38 min 55 sec, with the shortest interview lasting 14 min and the longest 2 hrs 12 min. The differences in the length of interviews were consequences of short and brief answers of the youngest participants (10-11 years old) and at the same time of long explanatory and deeply reflexive answers of the retired adult gymnasts, which sometimes as well overcome the question theme. The total duration of all interviews conducted with both active and retired female gymnasts was 24 hours. The total duration of all interviews

conducted with coaches was 8 hrs 9 min 45 sec, with an average interview lasting 54 min 25 sec.

The research was conducted according to ethical standards regarding human subjects and according to guidelines as outlined by the Helsinki-Tokyo Declaration. Personal data were collected and protected in compliance with the Personal Data Protection Act (2007). Ethical aspects of the research were discussed and approved in May 2010 by the Ethics Committee at the Department of Psychology, Faculty of Arts, University of Ljubljana. Before giving an interview, all respondents signed a *Consent form for participating in research on top-level achievements of children*. For minors, the form was also signed by their parents or legal representatives. All presented statements are coded, respecting the respondents' right to confidentiality and anonymity. Personal names, place names, specific periods and any other demographic data that could be used to identify the respondents were removed from the presented results.

To analyse the data, a phenomenological approach was adopted. This approach highlights typical respondent statements which generalize the findings and illustrate respondents' personal experiences with the researched phenomenon (Creswell, 2014). Subsequently, data were analysed using the qualitative content analysis (Adam et al., 2012). The latter method was used to analyse respondent statements for the main themes which explain how top-level achievements in women's artistic gymnastics are produced, according to both active and retired female gymnasts and their coaches.

RESULTS

In active female gymnasts, qualitative content analysis yielded eight main themes which illustrate the course and characteristics of their careers, such as the reasons for starting to train gymnastics, parents' role, characteristics of trainings and

competitions, balancing school and gymnastics, adverse events hindering elite-level achievements, gymnastics as a way of life, and development of gymnastic talent. In retired gymnasts, qualitative analysis yielded three main themes: identification of talent, development of talent, and legacy after career conclusion (Table 1).

Among *the reasons for starting to train gymnastics* and *ways of identifying gymnastic talent*, both active and retired gymnast respondents specified different factors including internal motives, invitation from a friend who was training, and the role of parents who recognized a child's talent or enrolled her because she was lively or because the gym was near. In addition, the coach played a very important role in the

selection of gymnasts throughout the researched period (1960-2013). In the 1970s and 1980s, many Slovenian elementary school children were selected to train gymnastics based on the results of systematic physical activity tests which were conducted by coaches from gymnastics clubs.

“Actually, we had this test in elementary school, it was in 1st grade during PE. A coach came and he would select the girls he thought might be good in gymnastics. Then he gave us some papers which said when, how, and why, and my parents brought me in just to try it out...”
(G-R-7/1)

Table 1

Qualitative content analysis of the life of active and retired gymnasts.

GROUP	THEME	CATEGORY
Active gymnasts	reasons for starting to train gymnastics	child's family recognizes gymnastic talent invitation from a friend PE teacher internal motives
	parents' role	active role of parents passive role of parents gymnastics as a way of life for the whole family
	training characteristics	criteria for selecting a gymnastics club importance of age at the start of training starting by playing gradual increase in the difficulty and the intensity of training problems at the start of more intensive training amount of training frequency of participation in trainings ensuring safety
	competitions	achievements in national competitions achievements in international competitions selection at the gymnastics club motivation for competitions role of a coach
	balancing school and gymnastics	adapting school schedule to gymnastics schedule selecting school to suit gymnastics trainings lack of time for school due to gymnastics peer support
	adverse events	fear of coach injuries psychological pressure exposure to violence
	gymnastics as a way of life	putting gymnastics first development of positive personal characteristics
	development of talent	chronological stages of development into an elite athlete
	doing it again	I would do it again indecision about going down the same path again I would not do it again
	making changes to past career	starting to train gymnastics earlier

		coming to training more often and being more active different approach to gymnastics training prevention of adverse events better reward system I would have chosen a different sport
	specific lifestyle of a gymnast	specific lifestyle role of society in promoting elite achievements
	identification of talent	motives personal characteristics important for gymnastics role of coach role of parents
	the process of making an elite gymnast/development of talent	factors involved in decision to sign up for artistic gymnastics trainings competitions factors involved in decision to conclude a career
Retired gymnasts	legacy after career conclusion	influence on physical and mental health influence on schooling good memories negative emotions after career conclusion gymnastics after concluding a career in elite sports
	doing it again	would absolutely do it again without changes would probably do it again positive memories positive influence on life
	making changes to past career	I would have persevered longer I would have put more effort into it I would have been more in touch with my inner self negative memories negative behavioural patterns in adulthood

Table 2.

Opinions of coaches on the appropriate age for a child to start training and competing in women's artistic gymnastics to produce top-level achievements.

THEME	CATEGORY	CODE
Starting age	start in pre-school age	starting age for elite gymnastics is four to five years
	no competitions at the beginning	very small children are not suitable for competitions mistakes are tolerated in very small children
	late start	few talented children succeed despite starting to train late extreme talents can learn gymnastics after the age of 10
Raising the age limit for entering the senior team to 18 years	age limit for competitions	in the past, age limit did not exist for competitions the first age limit for senior competitions in women's gymnastics was 14 years later, the age limit for senior competitions in women's gymnastics was raised to 16 years
	retaining existing age limit of 16 years	proposal to raise the age limit for women's senior gymnastics competitions to 18 years research results do not support raising the age limit existing age limit of 16 years for senior competitions is appropriate
	adverse consequences of raising the age limit	distrust that the age limit can successfully be raised difficulty of retaining elite-level form in women's gymnastics until the age of 18 more injuries are expected if athletes start training later more injuries on the vault influence of raising the age limit on smaller countries
	development possible even if the age limit is raised	development is possible even after the age of 16 it is possible to have top-level achievements after the age of 20
Age determines the course of career	pre-adolescence as the best period for learning	excellent conditions for learning before puberty no injuries before puberty faster regeneration before puberty

	greater psychological stability before puberty easier to lead children before puberty all gymnastics is taught up to the age of 16 easiest to teach a child between ages six and nine
age for top-level achievements	most appropriate age for top-level achievements in women's gymnastics is 16-20 years gymnast's age is important for obtaining top-level achievements
age determines career conclusion	career in gymnastics concludes at the age of 21, when it only begins in other sports

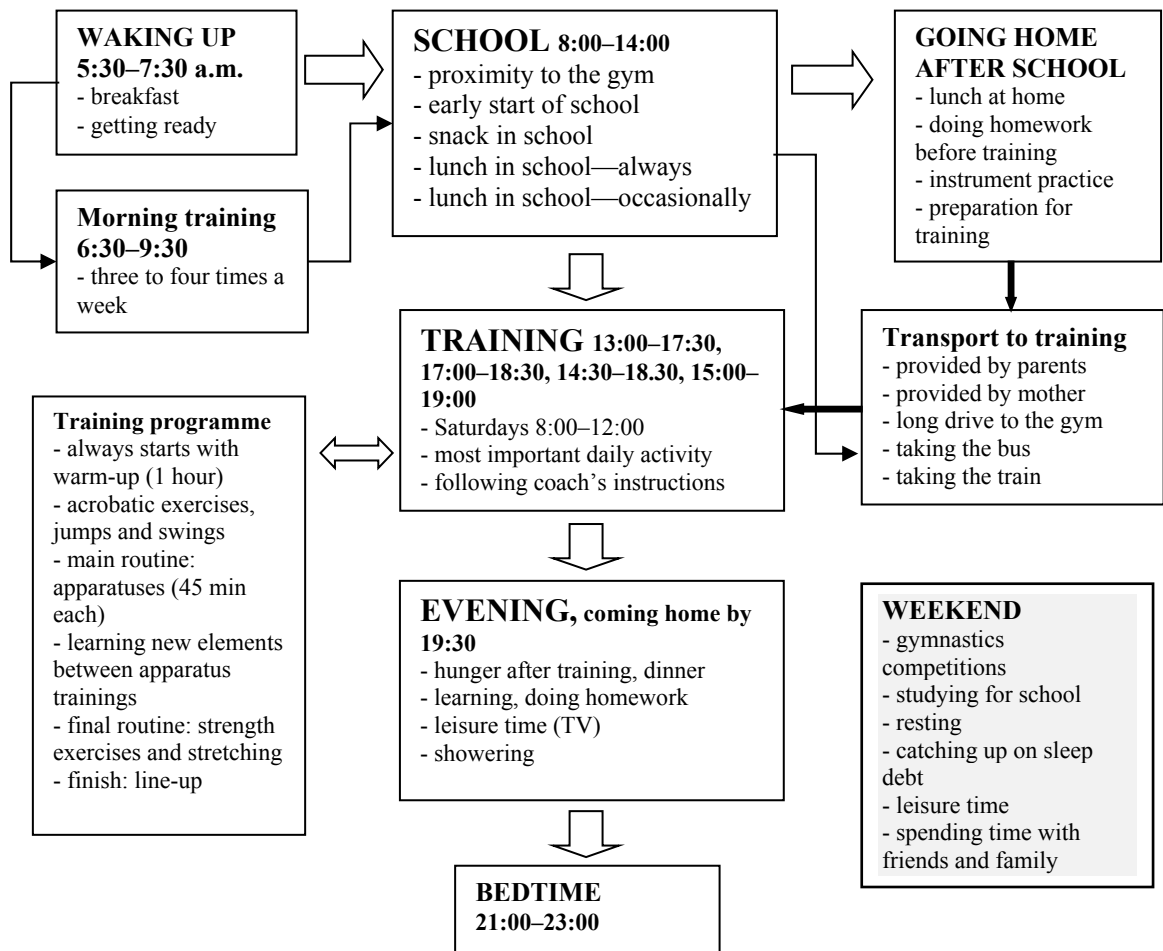

Figure 1. A typical day of an active female gymnast aged 9–14 years.

Nowadays, this kind of selection is no longer possible due to personal data protection laws. However, coaches continue to play an important role in selecting the younger female gymnasts who are still active. These are the PE teachers who work full-time at an elementary school and also coach girls part-time at a gymnastics club.

“First I was training at school, and then this coach who works here, at the time she still worked at my elementary school, she actually told me to go and check it out, because she thought I might be good in gymnastics, and that’s how it all started.”
(G-A-16/1)

The main activities in *developing the talent for gymnastics* are *trainings* and *competitions*. These were two of the strongest themes, both for active and retired female gymnasts. Active gymnasts stressed the importance of age when starting with the trainings—the younger a gymnast is, the more knowledge she can gain before starting with competitions. Being over seven years of age when starting to train was seen as a significant drawback by the gymnast respondents. Further, active gymnasts emphasized the amount and frequency of training to achieve success in competitions. The duration of training in childhood years ranges from three to six hours daily, and increases with age. When gymnasts are 9-14 years old, they have additional morning trainings and participate in annual preparation trainings in renowned gymnastics centres abroad. When it comes to taking part in competitions, the selection process at the local gymnastics club is very important, including the results of motor performance tests, advancement to a better group, and selection made by the coach.

“Then they put me in a better group, because we were doing jumps on the trampette and we were supposed to swing our arms once, but I managed to do it twice. So they put me in a higher level.” (G-A-18/1)

The statements from retired gymnasts, on the other hand, emphasized that training was above all a constantly changing process. The training programme changes together with the discipline itself, including the gymnastic apparatuses and elements—the latter kept getting more difficult, especially after 1970. In the 1970s and 1980s, the training of elite women’s artistic gymnastics would typically begin in school, where girls would practice twice a week. Then, after a month or two of easy exercises, the gymnasts were invited to a gymnastics club where the exercises quickly progressed to elite-level sports training. Respondents recounted that the system was very well thought out—they were cleverly directed from fun gymnastic games to elite sport, which, as children, they were neither

familiar with nor did they particularly desire.

“We started by having fun, and that’s how they got us. It was almost like a movie script; more and more, until we were practicing every day. We didn’t even particularly want that, I mean, we didn’t know something like training every day even existed.” (G-R-3/17)

The theme *competitions* underlined that gymnastics had always been a sport for young girls with a low age limit for entry into senior competitions. Even gymnasts who trained and competed in the first half of the 1970s obtained their highest competitive achievements from the age of 10 to the start of puberty.

“I was very successful, I was always the best or the second best, especially in my category. Because I always did that well, they’d immediately transfer me into a higher category. Even to this day, I’m still the youngest Yugoslav senior gymnastics team member. At the time, I wasn’t 11 years old yet, I turned 11 that year. That means I was just over 10 years old when I became a senior team member.” (G-R-2/1)

Active gymnasts also stressed the role of parents and full-time schooling, which is another obligation that runs parallel with gymnastics trainings. Despite enjoying the understanding of their teachers and the support of their parents and peers, gymnasts still stressed a lack of time for *full-time schooling* due to gymnastics, reflected by their sense of missing out on general education and a tougher transition to higher education. *Parents play an active role* by closely monitoring their child’s activities and progress in gymnastics, and seeking the best possibilities for the child’s gymnastic development. Often, parents would neglect their own needs or activities or even risk losing a job to adapt to the child’s schedule.

“I’m from another town ... [town name], so my mom would bring me in for practice in the morning at 6:30, I’d be there for an hour, until 7:30, then she’d take me back to school in our home town. I was in school from 8 a.m. to 1 or 2 p.m. Then I’d get right on the train, all the way to ...

[station name], and my mom would pick me up there and drive me here. We'd train from 2:30 to 7, then someone would pick me up and I'd come home by 7:30... My mom almost lost her job because she kept going out during her workday." (G-A-13/2-3)

Constant trainings and competitions mean that a gymnast's career can also be influenced by **adverse events** such as different health issues, especially injuries and the long-term rehabilitation they require. Interviews with retired elite female gymnasts revealed that athletes would get back to the gym as soon as possible, often before fully completing the rehabilitation process. In many cases, this led to a prolonged rehabilitation with permanent consequences for the gymnast's health after finishing their career.

"And then I injured my elbow, which means that I lost a year. I remember going to the trainings with a cast, we were doing strength exercises, but it wasn't the same anymore. And my elbow was ... well, it still is today, but now I can straighten it out, but then I couldn't straighten it out all the way, I couldn't bend my hand... I still feel my elbow when the weather's bad." (G-R-8/8-9)

Injuries were the most prominent adverse event in the development of an elite gymnasts also for active athletes. For example, injuries would cause them to miss out on a competition or to suspend their training and sports careers. In some athletes, injury occurred early on in their career and required long-term rehabilitation, making a comeback to elite sport very challenging.

"Overall, I was making really fast progress. When I was nine, I went for training in Russia for the first time, it was 17 days, and when I was 10, I went for my first international competition abroad [country name] and I was also first, I won the floor exercise that time... From then on, I was only making progress... until my first serious injury. The second operation was in 2011, and I've been trying to get back since then." (G-A-16/1)

When asked whether they would choose **the same career path in gymnastics again** if presented with an opportunity to start all over, knowing all the highs and lows they would have to face along the way, the answers of both active and retired gymnasts yielded two identical themes: they would take the same path again but they would also want to make some **changes**. Retired gymnasts emphasized that they would put more effort into their sports careers, listen to their inner voice more and persevere longer. They believe that all the effort invested during childhood years can only be fully capitalized on in adult gymnasts.

"I actually see that they're enjoying the competitions more, now that they're adult women. It's almost like they're reaping the reward of the hard work that they put in. Adult women experience these things totally differently than we did, we were just kids and they, well, they just somehow went by us." (G-R-11/13)

In contrast, active gymnasts substantiate their decision for making changes to their elite athlete careers with the **specific lifestyle** typical of gymnastics and marked by an absence of free time, an inability to select leisure activities, the sacrifices parents and other family members make to accommodate a child's sports career, a highly-intensive childhood, and an inability to understand the necessary lifestyle and training programme requirements for top-level achievements in childhood.

"Maybe the problem in gymnastics is that things tend to be most intensive when you're a child. You know, everything's strenuous anyway, like cycling, rowing or tennis, it's the same thing, you have to be away from home even more and stuff. But it's easier to accept that and understand it when you're 17 and you have to train a lot, than when you're 10 and someone tells you that you have to get up at six in the morning and go train, and you're like – what's wrong with you? If you're 17 and you have to do that, you have a different perspective."

That's the problem in gymnastics." (G-A-13/13)

Figure 1 shows the structure and sequence of activities in the normal day of an elite gymnast still active in competitive gymnastics. She begins by waking up between 5:30 and 7:30 a.m. and then goes to school, sometimes she has morning training before that. Morning training is usually not scheduled every day. Its duration ranges from one hour to one and a half hours, and up to two and a half hours in high school. School starts at 8 a.m. and finishes between 1 and 2 p.m. After school, younger gymnasts in lower grades of elementary school with a shorter daily schedule go home where they eat lunch, do their homework, engage in leisure activities and get ready for training. In contrast, gymnasts in higher grades of elementary school and in high school go to train immediately after school. Typically, the training would start between 2:30 and 3 p.m. Training is the main daily activity of gymnasts, conducted every day for an average of four hours with the exception of Sundays, which are meant for resting. When coming home from training, respondents report being very hungry, so dinner is the next activity on the list. In the evenings, gymnasts get ready for school, do their homework, and study. If there is any time left, particularly younger gymnasts in lower grades of elementary school like to spend it watching television. They go to bed between 9 and 11 p.m. As the amount of school work and the need for studying increase, they tend to go to bed later. Saturday mornings are reserved for training and possible competitions, and the rest of the weekend is spent resting, spending time with friends and family, and getting ready for school.

Because entering the world of women's artistic gymnastics is always closely related to a child's age, we were interested in the coaches' opinions on the right age for a child to start training gymnastics and to start performing in senior competitions if they are to produce top-level achievements. The results yielded three main themes (Table 2). As the first theme, coaches indicated *the*

starting age for training, with the best athletes starting to train in the pre-school period, usually between the ages of four and five. According to the coaches, very talented children who can have a successful career despite starting to train later are rare. However, even the most talented children should start gradually even though they get an early start—play is very important at first, there should be no competitions and no striving for perfection.

The second theme is *raising the age limit for entry into the senior team to 18 years*. Here, the coaches gave their opinions on changing the competition rules and, consequently, on changing the sport itself. Respondents expressed different opinions on the proposed changes. Some believe that there has to be a minimum age limit to compete in the biggest events and that gymnasts can advance even if the age limit gets raised.

"In the past, you could compete in senior competitions when you were 14, now the limit is 16 years. They're even thinking of raising it to 18 years because there's an increasing number of competitors aged 20, 25, even 30 years. But we're not at a point where only adult women would be competing, they still compete together with girls... When I was active, from 1972 to 1988, athletes would stop training when they turned 13 or 14. Today, there are seven girls in our club who are older than 16, and they're all seriously training gymnastics... It would definitely be good for gymnastics as a sport to have the age limit moved up to 18 years because it would give people a chance to work more gradually towards achieving something, no one would be in such a rush and coaches would take care of their athletes, they'd know that they have to be 18 before they can start competing." (G-U-2/1-2)

Conversely, others believe that the age limit should stay as it is. Coaches substantiate this opinion with research results and a disbelief that top-level achievements can be obtained if the age limit is raised. Coaches feel that it is difficult to retain elite-level form in

women's gymnastics until the age of 18. In addition, they predict more injuries due to a later starting age and issues on athletes' body recovery in post-adolescence. As a result, they believe that raising the age limit would place especially smaller countries in a disadvantaged position, wherein the main reason is smaller pool of elite athletes in the senior women's artistic gymnastics among countries with less population.

"This year, there was talk of raising the age limit to 18 years... In the end, that didn't happen because simply too many people complained... Until puberty, everything is great—there are no injuries and regeneration is much faster, kids that age almost never have sore muscles. Second of all, they're stable psychologically, they recognize authority and so on. As soon as they hit puberty, it's a disaster. Psychologically, they're totally unstable, they're searching for themselves, they want to prove themselves by going against the coach's authority, they fight... Also, they have issues with themselves, the way they look, they start to develop physically and so the centre of balance is off... The amount of fat tissue in girls increases greatly and so on... It's the end of the story." (G-U-1/4-5)

The third theme was **age determines a gymnast's career**. Here, we confirmed the opinion of coaches that the best developmental stage in women's artistic gymnastics for gaining new knowledge and skills, and for developing motor abilities, is pre-adolescence (six to nine years of age). Further, the best period for competing and producing top-level achievements according to the coaches is the period between 16 and 20 years of age. Coach respondents emphasized that a competitor's age is crucial for the ability to achieve top-level results and also represents one of the main reasons for concluding a career. They pointed out that a competitive career of female gymnasts concludes at 21 years, whereas in many other sports, that is the time when athletes start competing in major competitions.

"Actually, when they stop growing, that sadly also signals the end of their career."

It's not like men's gymnastics where the best results can be achieved also up to 30 or even 35 years. In women's gymnastics, the average age for getting the best results is 18 and 19 years, which means they have to start really early, like when they're four or five. That way, they get ten years for doing the complete gymnastics programme, and three to four years are spent only preparing for the biggest competitions." (G-U-3/1)

DISCUSSION

The empirical qualitative research conducted to determine the opinions of active and retired elite female gymnasts on their careers and top achievements in women's artistic gymnastics revealed that the respondents would do it again, regardless of the specific lifestyle they had to lead, the sacrifices they had to make, the adverse events they faced, and the consequences for their physical and mental health. Our findings identify the main factors connected with women's elite artistic gymnastics in terms of the role of a gymnast's age, the reasons for starting to train, the characteristics of trainings and competitions, a specific lifestyle reflected by a typical gymnast's day, balancing trainings and school, the role of parents, and possible adverse effects during and after a career.

Our research results showed that systematic physical activity tests for children, selection of a coach or a gymnastics club, and the role of parents who recognize their child's talent are the key factors for starting a career in gymnastics. According to Camporesi (2013), the decision on which sport to engage in should be left solely up to a child, without possible interests or life plans of their parents and other authority figures. However, strong competition interest between countries for medals and glory encourages development of procedures and tests for a sport talent identification. Pion et al. (2016) found that predictive models, which based upon non-linear objective statistics, improved the correctness of talent identification in

women's artistic gymnastics and reduce the risk of missing high-potential gymnast. Irrespectively of that findings, underlined the authors, no talent identification model is 100 % prognostic due psychological and environmental factors, which affecting the interaction between training and genetics. Therefore the developing a talent should not be justified with the benefits for society (Camporesi, 2013). As is clearly evident from the statements of retired gymnast respondents, they did not decide on elite gymnastics themselves. In fact, they were critical about the system being very well thought out, of how they were cleverly directed from children's gymnastics games to elite sport, which they were not familiar with as children. The United Nations Convention on the Rights of the Child emphasizes that the safety of children must also be ensured during their leisure activities: "States Parties recognize the right of the child to rest and leisure, to engage in play and recreational activities appropriate to the age of the child" (Convention on the Rights of the Child, 1989). With this article, the Convention ensures each child the right to engage in recreational activities appropriate for their age and preferences, which should primarily serve as play. Here, the issue of elite sports activities for children which start as leisure activities arises. In this case, recreational activities no longer serve their main purpose—for children to spend their free time resting, playing, and having fun—but quite the opposite: they become the central activity to which everything else must be sacrificed, starting with free time, schooling, and family activities. The children are isolated from their parents and the world outside of sport. Everything in children's life and in life of their families revolves around gymnastics (Smits et al., 2016).

A lack of time for school obligations due to gymnastics has also been reported in our research results. With a typical daily schedule of a gymnast between the ages of 9 and 14, we confirmed the lifestyle of elite female gymnasts which places sport in first place, without leaving time for leisure

activities or giving children the choice to select free-time activities themselves. When it comes to balancing a child's obligations and activities, parents play a key role. Salecl (2010) warns that, in the past 20 years, an opinion has formed regarding the upbringing of children that parents can influence their child's development by acting deliberately, and that the level of their engagement will influence the course of a child's life. Based on this, parents could encourage potentially dangerous endeavours in their children with the aim of obtaining fame or financial rewards. In its extreme form, achievement by proxy can even be a kind of child abuse (Tofler et al., 1996). The importance of parents in the elite youth sport brought to the surface in our empirical study confirmed as well other comparable studies. Smits et al. (2017) emphasized that female gymnasts' parents are crucial to make sense of a normalization of abusive coaching practices and ongoing "code of silence" in the elite artistic gymnastics. In their qualitative study, the parents uncritically and faithfully trusted in a coach's knowledge, behaviour and belief that makes the best for the gymnast. Authors argued therefore that a critical approach is needed. The parents need to learn how to ensure their voice is heard and taken seriously in the contextual gymnastics micro-frame between child athlete, coach and parents. Similarly, Burgess et al. (2016) in phenomenological study found out that normalising experiences and detaching from gymnastics are among main coping strategies of parents of elite female gymnasts aged 11-14 years. Nunomura and Oliveira (2013) based on 163 semi-structured interviews with Brazilian artistic gymnasts found out that parental support enabled and greatly influenced the child's entering into sports, their level of participation and achievements, and their physical and mental wellbeing. However, when parental support turns into negative way it can result in stress, conflicts, and child's burnout or even to dropout from gymnastics. Our phenomenological study equally confirmed the crucial role of parents

who recognized a daughter's talent and enrolled her into gymnastics training. Further, the parents play an essential role by supporting their child's activities and progress in gymnastics. Through this process, the parents face numerous organisational, competitive, and developmental stressors, such as already reported by Burgess et al. (2016) strongest stressors are coming from time and travel demands, schooling, finances, competitive pressure and injuries.

The main finding of our research, reflected by the interview statements of both active and retired gymnasts and their coaches, is the importance of age, which determines the sports career of a gymnast. Active gymnasts stressed the importance of the starting age, which significantly influences the range of gymnastic knowledge and skills, and can represent an important deficit perceived throughout the career if it is too high. As was confirmed in an interview with a retired member of the Yugoslav elite gymnastics national team who actively competed in the first half of 1970s, the age limit for entry into the highest level competitions was primarily determined by the sport achievements even before the so-called era of little girls. Regardless of age, coaches would sign up a high-achieving athlete for senior competitions. A contradictory attitude towards pre-adolescent performances at competitions at the highest level was identified in female gymnasts. While describing these performances as their highest achievements, which they reflect on with a certain pride and joy, they also believe that they started their gymnastic careers too early, and that they could not understand and enjoy the results of their work as children to the same extent as adult athletes. What is more, they admit not understanding the point of subordinating their entire lives to elite sport. Duarte et al. (2015) noted that early age of elite gymnast is great risk factor for experiencing the fear, especially fear of injury, fear of errors and failure, fear of apparatus, and fear of coach. To avoid the consequences of negative

emotions and behavioural patterns in adulthood is important to implement educational programmes for coaches geared towards child development, physical and mental well-being, and improved pedagogical training methods.

Similarly, the coaches of interviewed gymnasts agreed that a child's age determines a career in gymnastics, both its start and its conclusion. However, their opinions were divided on the topic of raising the age limit for entry into senior women's gymnastics competitions from the existing age of 16 years to 18 years. They are aware of the issues brought on by a lower age limit, and examples of top performances from elite gymnasts over 20 years of age also prove that it is possible to develop and achieve the highest results in competitive artistic gymnastics in adulthood. Yet, coaches strongly believe that the best period for gymnastic development in girls is between the ages of six and nine, followed by a competitive period between the ages of 16 and 20, which substantiates the existing age limit. According to Caine et al. (2013), the judges' rules of competition also play a crucial role when it comes to the age of elite artistic gymnast competitors. Namely, these rules define the strategies and work methods employed by coaches at gymnastics clubs. A reduction in the number of pre-adolescent girls in senior gymnastics competitions would thus be possible by changing the rules and raising the age limit in competitions. According to Donti et al. (2012), changing the judging criteria will diminish psychological pressures for absolute performance and body thinness at young age. Children who engage in elite sport in early childhood have to undergo early selection and specialization processes, they have serious obligations, participate in highly demanding training and competitions, and feel the weight of pressure and expectations. As such, they represent an extremely high-risk athlete group. Therefore, it is essential to set a minimum age limit for training and competitions of elite sport, which will

ensure children's fundamental rights and their sports safety in accordance with the United Nations Convention on the Rights of the Child (Farstad, 2006). On the other side, the need for implementation of more transparent and precise judging system it comes into spotlight. According to Bučar Pajek et al. (2011), the 'Real Time Judging System' as a new computer assisted system to record and display deductions from individual judges in real time, promises an efficient tool to increase the transparency and reliability of judging in artistic gymnastics.

The pressure for achieving the highest results at the earliest age is one of the biggest risk factors for the abuse of elite child athletes. The International Gymnastics Federation (FIG) investigated the age of Chinese female gymnasts competing at the Beijing Olympic Games in 2008. Their investigation was concluded with an allegation that the two-time Olympic gold medal winner He Kexin was only 14 years old during the Olympics, thus failing to meet the minimum age limit of 16 years set for women's senior gymnastics competitions (Ghaye, Lee, Shaw, & Chesterfield, 2009). The participation of pre-adolescent children in elite sport is connected with several adverse events also established in our research, such as physical and mental health issues, particularly injuries and the resulting long-term rehabilitation. Ivković et al. (2007) believe that the reason for injuries in women's sports is overtraining, the result of an imbalance between the intensity of training and insufficient recovery time due to deficient mechanisms of tissue repair. Similarly, a report on Swedish elite women's artistic gymnastics found cases of severe physical injury and mental trauma similar to those of abused women and workplace mobbing victims (Stier, & Blomberg, 2015). Burnout due to the pressures of elite sport was present early on, even with 16-year-old gymnasts. Similarly, semi-structured interviews with former Portuguese female gymnasts showed various kinds of abuses during their sporting

careers. Weight control, training/competing with injuries and corporal punishment emerged as key forms of exploitation, which athletes addressing as a normal practice in the elite women's artistic gymnastics (Pinheiro et al., 2014). Moreover, Gervis and Dunn (2004) claim that the consequences can even be perceived after a sports career. In their qualitative research on a sample of 12 retired elite athletes, including gymnasts, the authors established emotional and psychological issues which former elite child athletes associated with the coach's inappropriate attitude and behaviour.

Our research findings are very important also in light of the Youth Olympic Games, an international sport event for elite child and youth athletes. Guidelines of the Olympic Agenda 2020 emphasize the protection of human and child rights in sports, pointing out the need for an in-depth revision of previous Youth Olympic Games in Recommendation 25, and a revision of the Code of Ethics for more transparency, and responsibility for rights implementation and the wellbeing of athletes in Recommendation 32 (*Olympic Agenda 2020*, 2014).

An insight into the daily routines of elite female athletes revealed both best practices and adverse factors. The latter should be eliminated to ensure safe participation in sports and the development of a child's dispositions in women's artistic gymnastics. Based on our findings, we provide the following recommendations for working with talented female gymnasts:

- only children with an innate disposition should be directed towards elite sport;
- coaches should develop individual approaches for female athletes, based on a child's talent, character, and developmental and personal characteristics, and also encourage internal motivation;
- in elite women's gymnastics, a sense of self-control and responsibility for one's own decisions should be encouraged in a child to promote their physical and mental health. A child's opinions and feelings

expressed during training should be considered, and a partnership should develop in planning and implementing trainings;

- gymnastics training and school obligations should be systematically harmonized, both in terms of schedules and content;

- more attention should be paid to strategies for prolonging a career in gymnastics over the age of 18. In this respect, being familiar with and managing the factors connected with the reasons for concluding a gymnastics career in women is crucial. Appropriate models for training women's artistic gymnastics should be developed, enabling athletes to learn and master new elements also after the onset of puberty;

- an interdisciplinary team of experts should be included in the training process;

- coaches should be educated on the possible adverse effects of the coach-athlete relationship, such as verbal and physical violence, while at the same time, positive forms of interpersonal interaction such as support, understanding, and trust should be encouraged;

- gymnastics clubs should develop injury prevention strategies, including innovative didactic approaches to training, physical fitness of athletes, and approaches employed in the rehabilitation period. When athletes start training too soon after an injury without any adaptation to their routine, they tend to strain other body parts more, generally leading to further injury;

- establish a closer cooperation between health care and sports organizations in prevention activities and recognizing health issues in children and youth involved in elite sport;

- placing the interests of a child before all other interests in society. Establishing control over the interests of parents, coaches, gymnastics clubs, and the country. Actively fighting any political or otherwise biased preference in national team selection and the work of judges, and fighting any manipulation and abuse of children for the purpose of achieving better sports results;

- gymnastics clubs must designate an athlete's rights advocate to whom children can freely confide all the issues they are facing at the place where these issues arise;

- developing models of gymnastic professionalization, providing athletes with a monthly income and opening up possibilities for the career of a professional athlete upon completion of schooling.

A qualitative methodological approach was selected in our research, which is, according to Goldstein (2007), more suitable for researching human rights and well-being themes in different fields compared to a quantitative approach. The sample included 37 elite female artistic gymnasts. While our results definitely provide a priceless insight into the world of elite artistic gymnastics, the sample also has some limitations for the research, resulting in longer periods of data collection, and extensive, complete, and time-demanding processing of transcripts and qualitative data analysis. A selection of the respondents was made with the snowball sampling method, enabling a unique access and inclusion into a closed social community of elite gymnasts and their coaches. Ritchie and Lewis (2006) point out that sampling with the snowball method can also have specific limitations from the aspect of sample dispersion. This is a consequence of the approach where new sample members are suggested by the existing ones, with the latter usually suggesting friends or acquaintances who have similar experiences and characteristics to themselves.

In this research, we focused on the view of athletes and their coaches. The third observation aspect—parents of elite athletes—is also indispensable and equally important. According to Jacobs et al. (2017), directors of clubs and national sports federations as well play a large role in creating the specific sport culture. However, these actors have received relatively little attention from scholars in gymnastics science. Triangulation with an integration of quantitative and qualitative methods in future research can provide an insight into understanding the studied phenomenon from

the perspectives of all key stakeholders in producing elite child gymnastics achievements.

Finally, the time distance between active and retired gymnast active sports career should be taken in consideration. The retired gymnast trained and competed in the period between 1969 and 1997, which already represents 30 years of gymnastics development and changes. The interviews with active gymnasts took place in 2012/2013 school year. Consequently, our study captured more than four decades of women's artistic gymnastics history. Schiavon and Paes (2011) studied the formation process of the female gymnastics in Brazil from 1980 to 2004. Their findings showed that women's gymnastics made significant development in training changes over the years, in terms of financial, material, and human resources support. The code of points of the International Federations of Gymnastics (FIG) played a crucial role in creation of gymnastics training and competitions over the decades. In our studied period the major changes of competition rules were occurred, such as extinction of the highest score – perfect 10, withdrawn the compulsory routines, vaulting horse was transformed to vaulting table, the age limit for entry into senior competitions was changed from no limit to 14th and later to 16th years of age. In the future studies will be interesting to look more deeply on life experiences of active and retired gymnasts according to different history and cultural context of the period, in which they have active sports career.

REFERENCES

Adam, F., Hlebec, V., Kavčič, M., Lamut, U., Mrzel, M., Podmenik, D., Poplas Susič, T., Rotar Pavlič, D., & Švab, I. (2012). *Kvalitativno raziskovanje v interdisciplinarni perspektivi [Qualitative Research in the Interdisciplinary Perspective]*. Ljubljana: Institute for developmental and strategic analysis.

Brackenridge, C. H. (2010). Setting the challenge: The ethical and research context

of children's involvement in elite sport. In C. H. Brackenridge, & D. Rhind (Eds.), *Elite Child Athlete Welfare: International Perspectives* (pp. 13-19). London: Brunel University.

Bučar Pajek, M., Forbes, W., Pajek, J., Leskošek, B., & Čuk, I. (2011). Reliability of real time judging system. *Science of Gymnastics Journal*, 3(2): 47-54.

Burgess, N. S., Knight, C. J., & Mellalieu, S. (2016). Parental stress and coping in elite youth gymnastics: an interpretative phenomenological analysis. *Qualitative Research in Sport, Exercise and Health*, 8(3): 237-256.

Caine, D. J., Russell, K., & Lim, L. (2013). *Handbook of Sports Medicine and Science: Gymnastics*. Oxford: John Wiley & Sons, Ltd.

Camporesi, S. (2013). Bend it like Beckham!: The ethics of genetically testing children for athletic potential. *Sport, Ethics and Philosophy*, 7(2): 175-185.

Collins, T. (2012). The impact of child protection on high-performance British gymnastics. In C. H. Brackenridge, T. Kay, & Rhind, D., eds. (2012). *Sport, Children's Rights and Violence Prevention: A Sourcebook on Global Issues and Local Programmes* (pp. 94-98). London: Brunel University Press, Brunel University.

Convention on the Rights of the Child: General Assembly Resolution 44/25. (1989). New York: United Nations General Assembly. Retrieved September 9, 2015, from

<http://www.ohchr.org/en/professionalinterest/pages/crc.aspx>

Council of the European Union. (2009). *EU Guidelines: Human Rights and International Humanitarian Law*. Brussels: European Communities.

Creswell, J. W. (2014). *Research Design: Qualitative, Quantitative, and Mixed Methods Approaches*. Thousand Oaks, California: Sage Publications, Inc.

Donti, O., Theodorakou, K., Kambiotis, S., & Donti, A. (2012). Self-esteem and trait anxiety in girls practicing competitive and recreational gymnastics. *Science of Gymnastics Journal*, 4(1): 33-43.

Duarte, L. H., Carbinatto, M. V., Nunomura, M. (2015). Artistic gymnastics and fear: reflections on its causes. *Science of Gymnastics Journal*, 7(3), 7-21.

Ensalaco, M. (2005). The right of the child to development. In M. Ensalaco, & L. C. Majka (Eds.), *Children's Human Rights: Progress and Challenges for Children Worldwide* (pp. 9-29). Oxford: Rowman & Littlefield Publishers, Inc.

Farstad, S. (2006). *Protecting Children's Rights in Sport: The Use of Minimum Age*. Unpublished master's thesis, Fribourg, Switzerland: University of Fribourg.

Gannon, T. A., & Cortoni, F., eds. (2010). *Female Sexual Offenders: Theory, Assessment and Treatment*. Chichester, Great Britain: Wiley-Blackwell.

Gervis, M., & Dunn, N. (2004). The emotional abuse of elite child athletes by their coaches. *Child Abuse Review*, 13(3), 215-223.

Ghaye, T., Lee, S., Shaw, S. J., & Chesterfield, G. (2009). When winning is not enough: Learning through reflections on the »best-self«. *Reflective Practice*, 10(3), 385-401.

Goldstein, R. J. (2007). The limitations of using quantitative data in studying human rights abuses. In R. L. Callaway, & J. Harrelson-Stephens (Eds.), *Exploring International Human Rights: Essential Readings* (pp. 29-36). Boulder & London: Lynne Rienner Publishers, Inc.

Gretchen, K. (2010). Physical and emotional abuse of elite child athletes: The case of forced physical exertion. In C. H. Brackenridge, & D. Rhind (Eds.), *Elite Child Athlete Welfare: International Perspectives* (pp. 41-50). London: Brunel University.

Ivković, A., Franić, M., Bojanić, I., & Pećina, M. (2007). Overuse injuries in female athletes. *Croatian Medical Journal*, 48(6), 767-778.

Jacobs, F., Smits, F., & Knoppers, A. (2017). 'You don't realize what you see!': the institutional context of emotional abuse in elite youth sport. *Sport in Society*, 20(1), 126-143.

Jager Agius, I. (2014). Razvoj mednarodnega prava otrokovih pravic [Development of the international law on children's rights]. In I. Jager Agius (Ed.), *Otrokove pravice v Sloveniji: od normativnih standardov do učinkovitega varstva: Zbornik ob 25-letnici Konvencije o otrokovih pravicah [Rights of Children in Slovenia: From the Normative Standards to Efficient Safeguarding: Proceedings of the 25th anniversary of the Convention on the Rights of the Child]* (pp. XVII–XXVII). Ljubljana: Faculty of Social Sciences, FDV Publishing House, Ministry of Foreign Affairs of the Republic of Slovenia.

Lassiter, J. W., & Watt, C. A. (2007). Student coaches' knowledge, attitudes, skills, and behaviours regarding the Female Athlete Triad. *Physical Educator*, 64(3), 142-151.

Nunomura, M., & Oliveira, M. S. (2013). Parent's support in the sports career of young gymnasts. *Science of Gymnastics Journal*, 5(1), 5-17.

Olympic Agenda 2020: 20+20 Recommendations. (2014). Lausanne: International Olympic Committee.

Olympic Movement Medical Code [in force as of 1 October 2009]. (2009). Lausanne: International Olympic Committee Executive Board.

Papaefstathiou, M., Rhind, D., & Brackenridge, C. H. (2013). Child protection in ballet: experiences and views of teachers, administrators and ballet students. *Child Abuse Review*, 22(2), 127-141. Retrieved March 15, 2013, from <http://onlinelibrary.wiley.com/doi/10.1002/car.2228/abstract>

Pauolo, D. (2005). *Human Rights in Youth Sport: A Critical Review of Children's Rights in Competitive Sports*. London and New York: Routledge.

Pinheiro, M. C., Pimenta, N., Resende, R., & Malcolm, D. (2014). Gymnastics and child abuse: an analysis of former international Portuguese female artistic gymnasts. *Sport, Education & Society*, 19(4), 435-450.

Pion, J., Hohmann, A., Liu, T., Lenoir, M., & Segers, V. (2016). Predictive models

reduce talent development costs in female gymnastics. *Journal of Sport Sciences*, 7, 1-6.

Ritchie, J., & Lewis, J. (2006). *Qualitative Research Practice: A Guide for Social Science Students and Researchers*. London, Great Britain: Sage Publications, Ltd.

Sahlstrom, K. J., & Jeglic, E. L. (2008). Factors affecting attitudes toward juvenile sex offenders. *Journal of Child Sexual Abuse*, 17(2), 180-196.

Salecl, R. (2010). *Disciplina kot pogoj svobode [A Discipline as a Condition of Freedom]*. Ljubljana: Založba Krtina.

Smits, F., Jacobs, F., & Knoppers, A. (2017). 'Everything revolves around gymnastics': athletes and parents make sense of elite youth sport. *Sport in Society*, 20(1), 66-83.

Schiavon, L. M., & Paes, R. R. (2011). The formation of Brazilian female gymnasts taking part in the Olympic Games (1980-2004). *Science of Gymnastics Journal*, 3(1), 5-13.

Stier, J., & Blomberg, H. (2015). The quest for truth: The use of discursive and rhetorical resources in newspaper coverage of the mis(treatment) of young Swedish gymnasts. *Discourse & Communication*, 10(1), 65-81.

Stirling, A. E., & Kerr, G. A. (2012). Emotional abuse in Canadian sport. In C. H. Brackenridge, T. Kay, & D. Rhind (Eds.), *Sport, Children's Rights and Violence Prevention* (pp. 106-111). London: A Sourcebook on Global Issues and Local Programmes, Brunel University Press, Brunel University.

Sundgot-Borgen, J., & Torstveit, M. K. (2004). Prevalence of eating disorders in elite athletes is higher than in the general population. *Clinical Journal of Sport Medicine*, 14(1), 25-32.

Šelih, A. (2014). Konvencija o otrokovih pravicah – Magna Carta otrokovih pravic in njeno izvajanje v Sloveniji [Convention on the Rights of the Child—Magna Carta of children's rights and its implementation in Slovenia]. In I. Jager Agius (Ed.), *Otrokove pravice v*

Sloveniji: od normativnih standardov do učinkovitega varstva: Zbornik ob 25-letnici Konvencije o otrokovih pravicah [Rights of Children in Slovenia: From the Normative Standards to Efficient Safeguarding: Proceedings on the 25th anniversary of the Convention on the Rights of the Child] (pp. 3-28). Ljubljana: Faculty of Social Sciences, FDV Publishing House, Ministry of Foreign Affairs of the Republic of Slovenia.

Timpka, T., Finch, C. F., Goulet, C., Noakes, T., & Yammine, K. (2008). Meeting the global demand of sports safety: The intersection of science and policy in sports safety. *Sports Medicine*, 38(10), 795-805.

Tofler, I. R., Katz Stryer, B., Micheli, L. J., & Herman, L. R. (1996). Physical and Emotional Problems of Elite Female Gymnasts. *The New England Journal of Medicine*, 335(4), 281-283.

Zakon o varstvu osebnih podatkov: uradno prečiščeno besedilo [Personal Data Protection Act: Official Consolidated Version]. (2007). Official Gazette of the Republic of Slovenia 94/2007. Retrieved August 19, 2015, from <http://www.uradni-list.si/1/objava.jsp?urlid=200794&stevilka=4690>

Zurc, J. (2015). *Etični vidiki vrhunskih dosežkov otrok [Ethical Questions on Top Achievements of Children]*. Unpublished doctoral dissertation, Ljubljana: University of Ljubljana, Faculty of Arts.

Zurc, J., Rhind, D., & Lang, M. (2014). Safeguarding children from violence and abuse in Slovenian sport. In M. Lang, & M. Hartill (Eds.), *Safeguarding, child protection and abuse in sport: international perspectives in research, policy and practice* (pp. 78-87). London & New York: Routledge (Routledge research in sport, culture and society).

Corresponding author:

Joca Zurc, Assistant Professor
Home address: Oljčna pot 63A,
6000 Koper
Phone: +386 30 388 077
E-mail: joca.zurc@guest.arnes.si

INFLUENCE OF NEW ANATOMIC RING DESIGN ON PALM SKIN TEMPERATURE

Igor Pušnik¹, Ivan Čuk², Vedran Hadžič²

¹Faculty of Electrical Engineering, University of Ljubljana, Ljubljana, Slovenia

²Faculty of Sport, University of Ljubljana, Ljubljana, Slovenia

Original article

Abstract

Gymnastics ring is very old that remained unchanged by shape (there were more changes in material and diameter) for more than 100 years. We made two new ring designs - one with the straight part to handle and one with the anatomic part to handle. New ring designs were compared with the classic ones during long swings in hang. All rings were of the same diameter and material, while the light distance between the upper and the bottom ring diameter was the same. Eighteen subjects were tested. Variables used were body height, body weight, body mass index, palm width and palm length, grip strength, and palm skin temperature before and after the exercise. Results show that palm skin temperature drops during long swing in hanging positions and this temperature drop is the most prominent with the classic and the straight rings. The palm skin temperature changes are not related to body mass index, relative grip strength, hand width and hand length and it seems that reasons for lower palm skin temperature can be related to the position of hands above heart and the shape of rings. In the sense of preserving good kinaesthetic awareness of the hand grip, at least for school and recreational use, the anatomic bent rings seems to be a better choice than classic rings or rings with the straight part.

Keywords: *artistic gymnastics, thermography, hand, grip.*

INTRODUCTION

Gymnastic rings are the youngest male artistic gymnastic apparatus. However, at the beginning the design was triangular with the straight part for a handgrip (Eiselen, 1816) (Figure 1a). Soon it was changed into the circular design ("Nauk o telovadbi : vaje na orodji.," 1869) (Figure 1b) and at the World Championship in Prague (1907) gymnasts voted to use the circular rings design (Čuk & Karácsony, 2002). Since then the circular design was in use as well as defined and normed by the International Gymnastics Federations (FIG, 2015).

At the beginning the rings were made

of iron, covered with leather, later they were made of wood (Spieth, 1989). More than 100 years long tradition had never been tested, whether it deserves the title of the most ergonomic apparatus. FIG changed in the past many apparatus norms, and the last most prominent was a change from the vaulting horse towards the vaulting table, mainly to increase the safety of men and women gymnasts (Čuk & Karacsony, 2004). Data on injury rates by the body part or apparatus related injury vary from authors and countries from where they come. Lower limbs are most frequently injured, mainly

because of floor exercises, vaults and other apparatus dismounts, while the second most injured part are upper limbs (Lueken Lueken, Stone, & Wallach., 1993). From the practice rings are more often related to shoulders injuries, while wrists are not common injuries on rings, but there is no evidence how a ring design is related to injuries. According to Brewin, Yeadon & Kerwin (2000) rings must possess elastic properties in attempt to protect gymnast's joints and decrease the potential for injury. When a fist is formed for grasping, it forms an outward bowed shape that is almost exactly opposite to rings design (Figure 2a). The ring's circular design tends to concentrate weight and swinging forces

towards the middle finger, with compressing palm skin also towards the middle finger, which is a personal experience of the authors.

Initially we wanted to redesign the rings in order to adjust ring grip to more anatomical hand characteristics. Two designs were prepared, one with the straight part for a hand, as it was originally used (Figure 2b), and another with the anatomic hand placement (Figure 2c). All designs were made of ash wood with the diameter of 28 mm and the same light distance between the upper and the bottom ring diameter (as it is the norm by the FIG)(FIG, 2015).

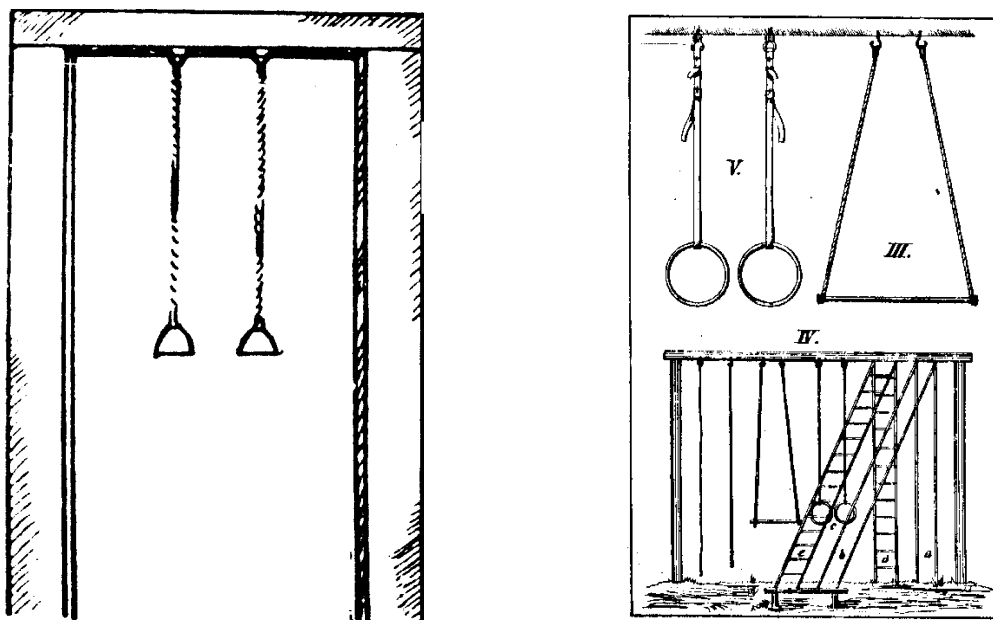

Figure 1. Shape of rings: a) triangular with the straight part – Eiselen 1844, b) circular – Nauk o telovadbi 1869.



Figure 2. a - palm grasp, b – rings with straight part, c – rings with bent part inward

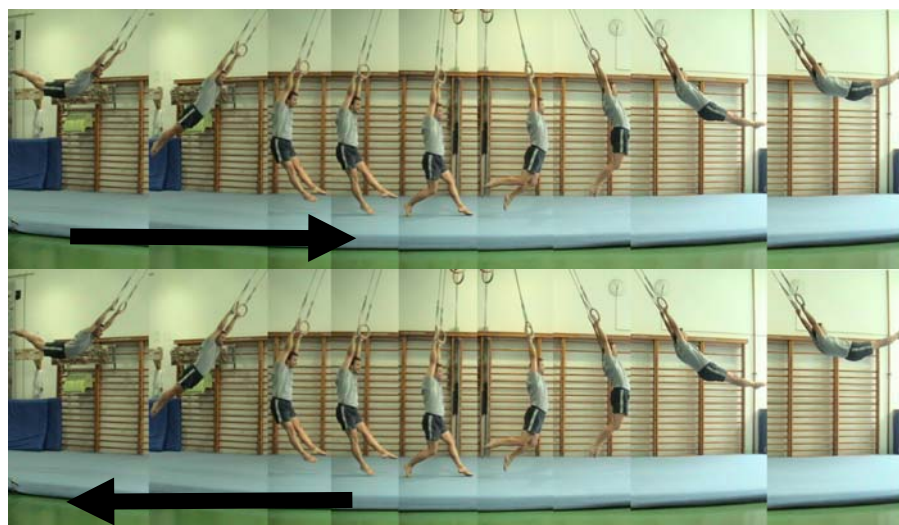

Figure 3. Full long swing from backward to forward and to backward position.

As we know, the change of apparatus in a professional sport is a very long process (Čuk & Karacsony, 2004). We aimed to test the new apparatus designs for beginners and recreational gymnasts with very simple gymnastic activity – full long swings - with appropriate time duration.

In gymnastics the upper extremities are used as weight-bearing limbs causing high tensile and compressive impact loads to be distributed through the elbow, wrist and palm. The shape of the ring and its physical characteristics may have an important impact on these loads in the sense of friction and pressure forces to the palm and down to the shoulder. These forces combined with consequent palm skin temperature changes are could be involved in the development of wrist and palm injuries in gymnasts. The wrist is the second most frequently injured site in male gymnasts (Caine, Maffulli, & Caine, 2008) from pommel horse and impact supports (vaulting etc.), while there is no data how a ring design is related to this facts. The change of temperature measured by a thermal imaging technique could predict also inflammation or injuries (Plassmann & Belem, 2009; Sands, McNeal & Stone, 2011). When a gymnast has the hand contact with the apparatus, certain physical load applies to the hand. The most common loads are the force of body weight,

grip force, friction force, and pressure. All of them have an impact on the change of palm skin temperature and with longer use also on palm injuries. Blisters are the most common palm injury. However, they are not mentioned among typical injuries, as they are not treated in medical centres (Dowdell, 2011; Sands, McNeal, Jemni, & Penitente, 2011).

According to Knapik, Reynolds, Duplantis & Jones (1995) blisters result from frictional forces ($F-f$) that mechanically separate epidermal cells at the level of the stratum spinosum. Hydrostatic pressure causes the area of the separation to fill with a fluid that is similar in composition to plasma but has a lower protein level. The magnitude of frictional forces ($F-f$) (which also produces heat) and the number of times that an object cycles across the skin determine the probability of blister development - the higher the $F-f$, the fewer number of cycles is necessary to produce a blister. Moist skin increases $F-f$, but very dry or very wet skin decreases $F-f$.

Gymnasts are using magnesium carbonate powder on their palms to make the handgrip with an apparatus safer (magnesium carbonate is very hygroscopic and dries palms). For simple gymnastic elements on wooden apparatus in duration of less than 10 seconds, use of magnesium

even rises the palm temperature, what makes use of magnesium carbonate slightly questioned in the sense of friction, but in the sense of lowering hand moisture its use is effective (Pušnik & Čuk, 2014). It is evident that exercise longer in duration should be performed with the use of magnesium carbonate. The aims of our research were to determine palm skin temperature change during the dynamic rings use, to determine which rings have more favourable design and to determine association between morphologic characteristics and grip strength with palm skin temperature change.

METHODS

Our sample consisted of 18 students (9 males and 9 females), all master degree students of physical education course, average age of 22.3 ± 1.2 years. All of them signed a written consent to participate in the experiment, according to the Helsinki declaration (WMA General Assembly, 1964).

We measured morphologic characteristics (body height (cm), body weight (kg), palm width (cm) and palm length (cm)) according to International Biological Program protocol (Weiner & Lourie 1981) on both sides, grip strength of left and right hand using a dial gauge hydraulic hand dynamometer (kg) (Lafayette professional hand dynamometer, model 503011, Lafayette Instrument Company, Lafayette, USA).

We measured chosen morphologic characteristics once as their reliability and validity is very high (Medved, 1980). For all subjects, we calculated Body Mass Index (BMI) and average results of the left and the right side regarding the palm width and the palm length. Grip strength was measured twice on the left and twice on the right side (Cronbach's alpha left 0.92, right 0.94). From the higher result on the left and the higher result on the right side grip strength we calculated the average. The reason to average the left and the right side values into joint variable was to lower bilateral differences (Čuk, Bučar Pajek, Jakše, Pajek

& Peček, 2012) as they can be also the reason for differences in palm skin temperature. We calculated the relative hand strength as the maximum strength divided by the body weight.

We measured skin temperature with the thermal imager FLIR 650sc with the wide angle lens of 45° , detector resolution 640×480 and adjustable instrumental emissivity in steps of 0.01. The spectral range of the detector is $7.5 \mu\text{m}$ to $13 \mu\text{m}$. The camera was calibrated in the range from 0°C to 70°C with the expanded uncertainty of 0.4°C . In metrology, measurement uncertainty is a non-negative parameter characterizing the dispersion of the values attributed to a measured quantity. All measurements are subject to uncertainty and a measurement result is complete only when it is accompanied by a statement of the associated uncertainty with a known probability. Expanded uncertainty in metrology usually covers the range of results with probability of 95 %. The choice of a thermal imager was from its characteristics because we wanted to measure temperature accurately (Grgić & Pušnik, 2011). For accurate temperature that a thermal imager is calibrated with appropriate calibration method (Drnovšek, Miklavec, Pušnik & Batagelj, 2013; Miklavec, Pušnik, Batagelj, & Drnovšek, 2011). Calibration was performed in the Slovenian national laboratory for thermometry (University of Ljubljana, Faculty of Electrical Engineering, Laboratory of Metrology and quality), where the thermal imager was calibrated against the blackbody, of which the temperature was determined with a set of standard platinum resistance thermometers all of them traceable to the International Temperature Scale ITS-90. The laboratory performances are stated in the Key Comparison Database (KCDB) of the International Bureau for Weights and Measures (BIPM) in Paris. Thermal images were acquired in the gym hall with temperature of 21°C and 45 % of relative humidity. In the analysis of thermograms the emissivity of skin with and without

magnesium carbonate was set to 0.97. There is a lack of data for emissivity value of magnesium carbonate in this temperature and spectral range. We estimated its value similar to skin emissivity based on other similar materials (e.g. plaster) and based on its powder condition. Despite the use of magnesium carbonate during the exercise, we measured the palm temperature before swinging. The emissivity of skin was unchanged because after the swinging most of hands were without magnesium carbonate and thus we recorded correct values of temperature.

We measured the maximum temperature with one thermal image of the right palm and the left palm (whole area of fingers and palm) before and after the load and calculated their difference. We measured temperature of both palms because we expected thermal asymmetry in subjects due to different grip force and due to natural temperature asymmetry (Vardasca, Ring, Plassmann, & Jones, 2012). The imager was positioned at a distance of 2 meters from the measured object and placed in such a way that sunlight was not direct into thermal camera. Digital thermal imaging of human skin is important tool for acquisition of temperatures (Jones & Plassmann, 2002). For further analysis we used as the maximum palm temperature the average maximum temperature of the left and the right palm.

On the measurement day, we measured first the morphologic data and grip strength. Subjects were in gym hall for 45 minutes to acclimate on air conditions before they started to exercise. After that a subject was asked to use magnesium carbonate according to his/her needs (as exercised in the past), then stand in front of the thermal imager to the exact position, which was determined with the line on the floor. When the thermal imager took a thermogram, a subject went to the rings and performed long swings. After the eight full long swings, a subject dismounted in the defined area (the same place as the starting position before the exercise on rings) and showed the

palms towards the thermal imager. A thermal image was taken 8 to 10 seconds after the dismount. Six subjects started with the exercise on the classic rings, six on the rings with the straight part and six on the anatomic bent rings, and then rotated to next rings to omit one sided skin exposure in a random fashion. Before and after each use of rings (classic, straight, anatomic) thermal image was recorded. Between each use of rings subjects had 20 minutes to rest. In each group were three males and three females.

Data were analysed using SPSS 22.0. Mean and standard deviations were used to present descriptive statistics following the Kolmogorov-Smirnov test for normality.

Pairwise t-test was used to evaluate the differences in palm temperature before and after the activity. Temperature difference (palm temperature after – palm temperature before activity) was also calculated and compared between different types of rings used in the study. Linear regression analysis was used to evaluate the possible correlations between palm temperature change on different ring types and body mass index, hand length, hand width and relative grip strength. All statistical significance was set at $p < 0.05$.

RESULTS

Kolmogorov-Smirnov test confirmed that all data were distributed normally. Table 1 represents the main demographic and anthropometric characteristics of the sample.

The linear regression analysis has shown that there are no statistically significant correlations between used predictors (body mass index, hand length and width and relative grip strength) and palm temperature difference measures on classic ($F=1.08$, $p=0.40$), straight ($F=1.41$, $p=0.28$) or anatomic rings ($F=0.69$; $p=0.61$).

DISCUSSION

The main results of our study are indicating that there is a statistically

significant palm temperature drop following the activity on gymnastics rings of different shapes (Table 2). In general while performing long swings palm skin temperature is lowering, although one would expect a temperature increase following the activity. One of the possible explanations of this observation is probably the hang position on rings where palms are kept highly above heart (more than 70 cm) causing a disturbance in blood flow to the hand. Low hand skin temperature was

correlated with decrements in handgrip strength (Cheng, Shih, Tsai, & Chi, 2014) and has a negative effect on tasks which require speed, encouraging erroneous responses (Enander, 1987). Although, those studies were dealing with much lower palm skin temperature (14 °C and 5 °C, respectively) than were observed in our study they can still point out the possible consequences of the longer duration exercising on rings in hang position.

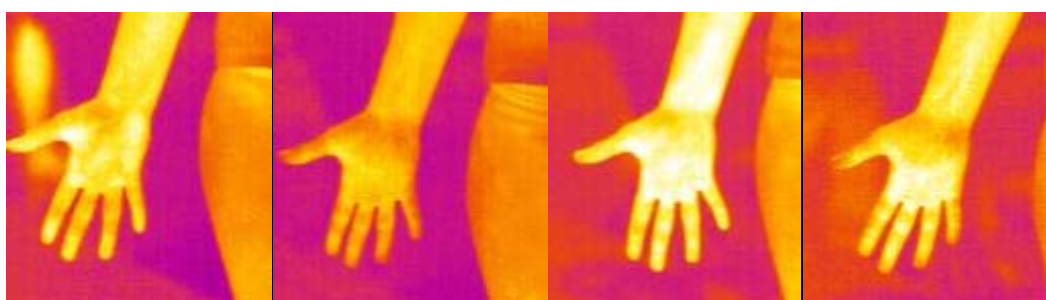

Figure 4. Same person right palm skin temperature classic rings (pre and after) and anatomic rings (pre and after)

Table 1

Main demographic and anthropometric characteristics of the subjects.

	Mean	Std. Deviation
Height (cm)	174.4	9.0
Weight (kg)	69.7	10.4
BMI	22.8	2.3
HandWidth (cm)	7.9	0.40
HandLength (cm)	19.1	0.91
RelativeFmax in body weight)	0.38	0.07

Table 2

Palm skin temperature before and after activity.

Ring type	Palm temperature (°C) ± Std. Dev.		Difference (°C)	t	Sig.
	Before	After			
Classic rings	33.28 ± 3.08	31.81 ± 2.99	1.46*	4.54	0.00
Straight rings	33.10 ± 2.73	31.84 ± 3.06	1.25**	6.19	0.00
Anatomic rings	32.71 ± 3.1	32.03 ± 3.05	.68	3.50	0.00
Pairways t-test					
Classic	: Anatomic		0.78 ± 1.54	2.15	0.04
Straight	: Anatomic		0.57 ± 0.99	2.45	0.02

Furthermore, we have also noticed some significant differences between ring types. While classic and straight ring types have shown similar temperature drops, the anatomic designed ring type caused a less temperature drop comparing to classic and straight ring type (Table 2). If high temperature drops may be indirectly related to poor performance as discussed above, than it seems that changing the ring type to anatomic type could have a positive effects on the athlete performance as the effects of palm temperature changes are not so prominent than with e.g. classic rings. The results of linear regression analysis further support this hypothesis, as predictors (such as BMI, hand width and length and grip strength) that could theoretically explain palm temperature changes were actually not correlated with these changes ($p > 0.05$ for all instances).

Although researchers (Seo & Armstrong, 2008) have reported that normal force and contact area can be explained by the interaction between handle size and hand size it was not the case in our study as all rings used in the study were of same diameter of 28 mm and hand size could not have been a reasons for the observed palm temperature drops. Design of handles (e. g., shape, size, and surface) may help to increase people's torque strength, and elliptic handle shape shows as the best (Seo & Armstrong, 2011), in sense of elliptic handle shape we can state anatomic rings.

One of the drawbacks of our study is the fact that we did not measure friction and therefore we can only speculate about its effects in the light of our results (temperature drop). Prior to the experiment we expected that for wooden rings and very dry hands (palm with magnesium carbonate) friction should be reasonably high (O'Meara & Smith, 2002; Pušnik & Čuk, 2014) to cause an increase in palm temperature. However, the result of our study did not support our initial expectations and it seems that other factor could override the friction

effect. Yamakoshi (2010) found that during kart racing, where handgrip must be firm, blood pressure measured with wrist sphygmomanometer significantly decreases immediately after the race. As mentioned above, one of the possible explanations of palm temperature drop could be the change in the palm blood flow during ring swings in hanging position. To evaluate this hypothesis we suggest that future studies should include a measurements of mean volume flow through radial artery using a duplex Doppler ultrasound as this method was used in other studies to evaluate the blood flow through radial artery (Kim et al., 2012). Our preliminary results (now shown) based on a single subject case study points toward the ring shape related changes in the blood flow during the static hanging on the ring.

CONCLUSIONS

In conclusion our results show that palm skin temperature drops during swing in hanging positions and this drop is most prominent with classic and straight rings. The palm skin temperature changes are not related to body mass index, relative grip strength, hand width and hand length and it seems that reasons for lower palm skin temperature can be related to the position of hands above heart and shape of rings.

In the sense of preserving good kinaesthetic awareness of the hand grip at least for school use and recreational use the anatomic bent rings seems to be a better choice than classic rings or rings with the straight part.

LIMITATIONS

The idea of rings with a different shape was predominantly prepared to serve better recreational gymnasts and school pupils with bare palms. It is not known what would be the effect of use handgrips and this can be the next stage in exploring of the new

rings design. Also as we did not measure the support activity, therefore we can not confirm the new rings design as a superior in general terms.

ACKNOWLEDGEMENT

The authors acknowledge the financial support from the Slovenian Research Agency (research core funding No. P5-0147 Kineziologija monostrukturnih, polistrukturnih in konvencionalnih športov).

REFERENCES

- Brewin, M. A., Yeadon, M. R., & Kerwin, D. G. (2000). Minimising peak forces at the shoulders during backward longswings on rings. *Human Movement Science, 19*(5), 717-736.
- Caine, D., Maffulli, N. & Caine, C. (2008). Epidemiology of Injury in Child and Adolescent Sports: Injury Rates, Risk Factors, and Prevention. *Clin Sports Med, 27*(1), 19-50. doi:10.1016/j.csm.2007.10.008
- Cheng, C.-C., Shih, Y.-C., Tsai, Y.-J. & Chi, C.-F. (2014). The influence of cooling forearm/hand and gender on estimation of handgrip strength. *Ergonomics, 57*(10), 1499-511. doi:10.1080/00140139.2014.934298
- Čuk, I., Bučar Pajek, M., Jakše, B., Pajek, J., Peček, M. (2012). Morphologic bilateral differences of top level gymnasts. *International journal of morphology, 30*(1), 110-114.
- Čuk, I. & Karácsony, I. (2004). *Vault: methods, ideas, curiosities, history*. Ljubljana: ŠTD Sangvinčki.
- Čuk, I. & Karácsony, I. (2002). *Rings: Methods, Ideas, Curiosities, History*. Norman: Paul Ziert & Assoc.
- Dowdell, T. (2011). Is gymnastics a dangerous sport in the Australian club context? *Science of Gymnast Journal 3*(2), 13-15.
- Drnovšek, J., Miklavec, A., Pušnik, I. & Batagelj, V. (2013). A large aperture blackbody bath for calibration of thermal imagers. *Meas Sci Technol, 24*(2), 25001. doi:10.1088/0957-0233/24/2/025001
- Eiselen, E.W.B. (1816). *Die deutsche Turnkunst zur Einrichtung der Turnplätze*. Selbstverlag, Berlin.
- Enander, A. (1987). Effects of moderate cold on performance of psychomotor and cognitive tasks. *Ergonomics, 30*(10), 1431-45. doi:10.1080/00140138708966037
- FIG. (2015). *Apparatus Norms*. Laussane: FIG
- Grgić, G. & Pušnik, I. (2011). Analysis of Thermal Imagers. *Int J Thermophys, 32*(1), 237-247. doi:10.1007/s10765-011-0932-z
- Jones, B.F. & Plassmann, P. (2002). Digital infrared thermal imaging of human skin. *IEEE Eng Med Biol Mag 21*(6), 41-48. doi:10.1109/MEMB.2002.1175137
- Kim, S.Y., Lee, J.S., Kim, W.O., Sun, J.M., Kwon, M.K. & Kil, H.K. (2012). Evaluation of radial and ulnar blood flow after radial artery cannulation with 20- and 22-gauge cannulae using duplex Doppler ultrasound. *Anaesthesia, 67*(10), 1138-45. doi:10.1111/j.1365-2044.2012.07235.x
- Knapik, J.J., Reynolds, K.L., Duplantis, K.L. & Jones, B.H. (1995). Friction blisters. Pathophysiology, prevention and treatment. *Sports Med, 20*(3), 136-147.
- Lueken, J., Stone, J. & Wallach, B. (1993). Olympic training centre report men's gymnastics injuries. *Gymnast Saf Updat, 8*(1), 4-5.
- Medved R. (1980). *Sportska medicina [Sports medicine]*. Zagreb: Jumena.
- Miklavec, A., Pušnik, I., Batagelj, V. & Drnovšek, J. (2011). Calibration of Thermal Imagers by Evaluation of the Entire Field-of-View. *Int J Thermophys, 32*(11), 2600-2609. doi:10.1007/s10765-011-1043-6
- Nauk o telovadbi: *Vaje na orodjih*. (1869). Ljubljana: Matica slovenska.
- O'Meara, D.M. & Smith, R.M. (2002). Functional handgrip test to determine the coefficient of static friction at the hand/handle interface. *Ergonomics, 45*(10), 717-31. doi:10.1080/00140130210159247
- Plassmann, P. & Belem, B. (2009). Early detection of wound inflammation by

colour analysis, in: Schaefer, G., Hassanien, A., Jiang, J. (Eds.), *Computational Intelligence in Medical Imaging* (89–112). Taylor & Francis.

Pušnik, I. & Čuk, I. (2014). Thermal imaging of hands during simple gymnastics elements on the wooden bar with and without use of magnesium carbonate. *Science of Gymnast Journal*, 6(1), 67–72.

Sands, W.A., McNeal, J.R., Jemni, M. & Penitente, G. (2011). Thinking sensibly about injury prevention and safety. *Science of Gymnast Journal*, 3(3), 43–58.

Sands, W.A., McNeal, J.R. & Stone, M.H. (2011). Thermal imaging and gymnastics injuries: a means of screening and injury identification. *Science of Gymnast Journal*, 3(2), 5–12.

Seo, N.J. & Armstrong, T.J. (2011). Effect of elliptic handle shape on grasping strategies, grip force distribution, and twisting ability. *Ergonomics*, 54(10), 961–970. doi:10.1080/00140139.2011.606923

Seo, N.J. & Armstrong, T.J. (2008). Investigation of grip force, normal force, contact area, hand size, and handle size for cylindrical handles. *Hum Factors*, 50(5), 734–744. doi:10.1518/001872008x354192

Spieth, R. (1989). *Die Geschichte der Turngeräte*. Herausgeber: Rudolf Spieth.

Vardasca, R., Ring, E.F.J., Plassmann, P. & Jones, C.D. (2012). Thermal symmetry of the upper and lower extremities in healthy subjects. *Thermol Int*, 22(2), 53–60.

Weiner, J.S. & Lourie, J.A. (1981). *Practical Human Biology* (International Biological Programme Handbook No. 9). London: Academic Press INC Ltd.

WMA General Assembly (1964). *World Medical Association Declaration of Helsinki*. World Med Assoc.

Yamakoshi, T. (2010). Physiological measurements and analyses in motor sports: A preliminary study in racing kart athletes. *European Journal of Sports Science*, 10(6), 397–406.

Corresponding author:

Igor Pušnik
Tržaška 25
1000 Ljubljana
phone: +386 1 4768 224
e-mail: igor.pusnik@fe.uni-lj.si

THE EFFECT OF TRAINING IN MAXIMAL ISOMETRIC STRENGTH IN YOUNG ARTISTIC GYMNASTS

George C. Dallas¹, Paschalis Kirialanis², Costas G. Dallas¹, Vassilis Mellos³

¹Kapodistrian University of Athens, School of Physical Education and Sport Science, Athens Greece

²Komotini, Greece

³University of Thessaly, Physical Education and Sport Science, Trikala, Greece

Original article

Abstract

Different methods have been developed for assessing muscle strength of various limbs in sport performance. The purpose of this study was to examine the maximal voluntary isometric strength in 57 young male gymnasts and 74 non-gymnasts. They were tested for isometric strength during force flexion and extension of upper and lower limbs during a 5-seconds maximal voluntary isometric strength for the right and left side respectively. The results showed significant differences between gymnasts and non-gymnasts ($p < .05$). Further, significant interaction revealed: a) for right side with respect to the force flexion at the elbow and shoulder joints; b) for the left side with respect to the force flexion for the elbow, shoulder and hip joint, c) with respect to the force extension of the right side for the elbow, shoulder, hip and knee joints, d) for the extension of the left side for elbow, shoulder, and hip joints. The above results must be taken under consideration by trainers seeking to improve the strength and overall training level of their athletes.

Keywords: muscular strength; isometric contraction; artistic gymnastics.

INTRODUCTION

Artistic gymnastics (AG) is a very difficult and complicated sport activity that involves bounding, jumping, tumbling, vertical landings, as well rapid accelerations and decelerations movements, which evoke high-impact loading strains, high strains rates and varied strain distribution patterns on the skeleton (Daly, Rich, & Bass, 1999; Dowthwaite & Scerpella, 2009; Farana, Jandacka, Uchytel, Zahradnik, & Irwin, 2014). Additionally, the permanent increase of exercises difficulty in various apparatus demand from early age the development of muscular strength in static strength elements

(cross, blanche, Japanese handstand, e.t.c.) as well in dynamic conditions as an impact velocity of 8.5m/sec generate ground reaction forces which have been measured from 8 to 18 times body weight (McNitt-Gray, 1991; Osguven, & Berne, 1988). Gymnasts alone will not develop an adequate level of strength for advanced gymnastics that means a highly developed level of performance cannot be maintained even by intensive performance of the event itself (Bührle, & Werner, 1984). Muscular strength increases fairly linearly with chronological age from early childhood

until approximately 13 or 14 years of age (mid-puberty) in boys (Parker, Round, Sacco, & Jones, 1990). The old notion that children could not benefit from resistance training due to inadequate levels of circulating androgens is not in valid (Faigenbaum, Kraemer, Cahill, & Roberts, 1996; Faigenbaum, Westcott, Loud, & Long, 1999; Sadres, Eliakim, Constantini, Lidor, & Falk, 2001; Stone, Sands, Carlook, Callan, Diokie, Daigle, Hartman, et al, 2004). At present, medical and fitness organizations support children's participation in appropriately designed and competently supervised youth resistance training programs. Children's that had following several weeks of strength training have reported significant improvements in strength (ACSM, 2000; Faigenbaum et al, 1996; Ramsay et al, 1990; Sewall, & Micheli, 1986; Weltman et al, 1986). Previous studies support that untrained children can enhance their upper-body strength and local muscle endurance by participating in a progressive resistance training program (Faigenbaum et al, 2001). Also, heavy-resistance training (or submaximal workloads, increase repetitive strength performance) is capable of enhancing single-repetition strength performance at maximum workloads (Hickson, Hidaka, & Foster, 1994; Hickson, Dvorak, Gorostiaga, Kurowski, & Foster, 1998). Fukunaga and his colleagues (1992) reported significant increases in upper arm isometric and isokinetic strength and lean (muscle and bone) cross-sectional area determined by ultrasound in preadolescent boys. The Position Statement on Youth Resistance Training published by National Strength & Conditioning Association from US upheld the more recent belief that properly supervised and well planned resistance training can be effective & safe in improving the strength of preadolescent and adolescent populations (Naughton, Farpour-Lambert, Carlson, Bradney, & Van Praagh, 2000). Currently different form of dynamometers such, isometric, isokinetic and isotonic dynamometer are used to assess muscular function with each form has its

drawbacks. The stationary knee muscle dynamometer has shown to be more reliable in assessing knee muscle strength than hand-held dynamometer (Tood, German, & Gandevia, 2004). Muscle power has been limited to measuring only dynamic exertion in which work-amount appears as an external movement, because it has been generally evaluated from the dynamic workload or the rate of workload. Static muscular contraction has excluded the concept of muscle power, since the dynamic workload with static contraction is zero (0), and attention has focused only on evaluating maximal muscle strength (MAX).

Isometric tests are generally performed to quantify the maximal force and/or the maximal rate of force development (Hakkinen, & Komi, 1986). However, analysis of the developmental phase (the initial phase until reaching the maximal force) of the force-time curves during static explosive strength exertion has revealed the existence of individual differences and gender differences. For example, when a person exerts a static explosive strength maximally and rapidly, even if the peak force, namely maximal muscle strength (MMS), is the same, individual differences is found in the time to reach and there are people who can rapidly reach MMS and those who cannot (Demura, Yamaji, Nagasawa, & Minami, 2000). Several studies have investigated the effect of different types of training program in development of strength during pre-pubertal ages (during pre-adolescent). Data of Docherty and his colleagues (1987) has reported no significant strength gains after the intervention of a strength training program. On the contrary, numerous other studies comparing strength trained children with age and sex matched controls have shown strength gains are possible (Ozmun, Mikesky, & Surbukg, 1994; Mellos Dallas, Kirialanis, Fiorilli, & Di Cagno, 2013). To the best of our knowledge only few studies have evaluate muscular strength of gymnasts during training period. In all sports, the physical strength of both boys and girls of ages up to 11 years are similar

whereas from 12 to 14 years, the boys are stronger than the girls (Maffulli, King, & Helms 1994). Parket et al. (1990) concluded that for non-athletic boys and girls, the isometric muscle strength increases continually until the age of 20. However, it has not been established whether this is the same for athletes. According to Maffulli, King, & Helms (1994) a plateau was observed for girls athletes at the age of 18 whereas the muscle strength of boy athletes continued to increase at the age of 18. Bassa and his colleagues (2002) have described the isometric and isokinetic knee torque in pre-pubescent male gymnasts six months after the beginning of the annual training period. To the author's knowledge there is a lack of data according the evaluation of isometric muscle strength after the end of the annual training period. Additionally, there are not previous studies that compare these results with those of previous annual training period in order to examine the level of improvement in isometric muscle. The main hypothesis of this study was that gymnastics training produces significant improvement on maximum isometric strength in young male gymnasts. Thus, the purpose of this study was to examine the effects of training on maximum voluntary isometric strength (MVIS) in young male gymnasts and to compare these results with the corresponding of previous annual training period.

METHODS

Fifty-seven pre-adolescent gymnasts (age: 10.00 ± 0.82 years; body mass 29.89 ± 4.02 Kg; body height: 131.88 ± 7.21 cm) and 74 non gymnasts (age: 10.00 ± 0.63 years; body mass 36.20 ± 4.04 Kg; body height: 137.19 ± 7.22 cm) volunteered to participate in this study. Gymnasts had a 4.5 ± 1.0 training experience and they were from different gymnastics clubs from North Greece. Non gymnasts were students of elementary school that they had not any sport activity except lessons-courses of physical education. Both the children and their parents were informed about this

research project and parental written consent was obtained. The study was designed according to the Declaration of Helsinki and was approved by the local Ethics Committee. The following exclusionary criteria were used: (a) children with a chronic pediatric disease, (b) children with an orthopedic limitation, and (c) children older than 12 years of age at the beginning of the study.

Participants had followed training programs of their clubs during their five years training with a frequency of 3 hours per day, for six days per week. Two measurements were performed, each one after the end of the annual training competition period, in order to evaluate the effectiveness of the current training program. Subjects were instructed, orally and in writing prior to first testing. All subjects participated in familiarization practice, organized before the testing procedures. During this time, they were taught the proper technique on each testing exercise, and any questions they had were answered. The strength testing was performed between 8am and 12 noon with the same investigators performing each test. A Kin-Com dynamometer (Kinetic Communicator II: Chattecx Corp, 101 Memorial Dr, Chattanooga, TN 37405) (Farrell, & Richards, 1986) was used to measure maximum voluntary isometric force (N) for elbow, shoulder, hip, and knee in flexion and extension of these joints. MVIS for the above muscles was measured on a dynamometer chair on which subjects were tested in a 90 degree angle during extension-flexion on both side in the following joints: elbow, shoulder, trunk, hip and knee (Era, Lyyra, Viitasalo, & Hikkinen, 1992; Kanehisa, & Miyashita, 1983). A great number of technical gymnastic skills are characterized by the application of isometric strength in order to preserve the body position, especially during static exercises as: standing scale in floor exercises, L-sit or straddle sit on various apparatus (still rings, parallel bars) hanging or support scales on still rings, e.t.c. During warm-up and especially at the end of

a training session, gymnasts execute special types of isotonic or isometric exercises, e.g. handstand push up in bands, press to handstand, windshield wipers, levers, arch-hollow throws, e.t.c., in order to improve the muscular strength of various parts of the body.

Triplicate measures for five muscle groups were obtained with the highest values reported. Adequate test periods of three minutes were given between tests to ensure that the subjects' initial performance on each test was not affected by muscle fatigue. The strength's tests were performed from "different body positions" according to the joints measurements. In all cases Velcro straps were used to stabilize the peripheral joints of participants. All subjects performed 10 minutes of stretching exercises before all testing and training procedures. All testing procedures were closely supervised, and uniform encouragement was offered to all subjects. After 5 min recovery each subject performed 3 trials for maximum isometric effort for extension and flexion of 5 seconds (Surakka, Virtanen, Aunola, Maentaka, & Pekkarinen, 2005) for the above mentioned

joints. All three trials were used for the assessment of reliability, while the trial with the best value (Fmax) recorded and used for further statistical analysis.

A two-way MANOVA (group x measurement) with repeated measures on both factors was used followed by post-hoc pair wise comparisons with Bonferroni corrections of age groups within each athletic level and of athletic levels within each age group. The level of significance was set at $p < 0.05$. All values are presented as means \pm SD. Interclass reliability coefficients were calculated and the respective results are presented in table 1.

RESULTS

Table 2 summarizes the means of maximum isometric voluntary strength of Force flexion in various joints. It is obvious that training had a positive effect on force increment in both groups except for flexion on left elbow in gymnasts. Moreover, percentage improvement was greater in non gymnasts compared with gymnasts.

Table 1.

Interclass reliability analysis for the force flexion and extension assessment of strength.

	<u>Flexion</u>	<u>Extension</u>
Elbow	.693	.683
Shoulder	.764	.764
Hip	.692	.692
Knee	.662	.669

Table 2

Maximum isometric voluntary strength of the sample of Force flexion (N).

	Gymnasts		Non Gymnasts	
	Measurement	Measurement	Measurement	Measurement
	1	2	1	2
F flexion right elbow	13.76 \pm 4.85	14.64 \pm 6.01	10.89 \pm 3.83	14.92 \pm 6.78
F flexion right shoulder	17.73 \pm 5.98	18.17 \pm 7.36	12.39 \pm 4.49	16.34 \pm 7.55
F flexion right hip	18.69 \pm 5.54	22.33 \pm 8.64	14.15 \pm 4.03	15.51 \pm 5.90
F flexion right knee	10.80 \pm 4.14	13.67 \pm 6.07	9.53 \pm 2.86	13.00 \pm 5.34
F flexion Left elbow	13.97 \pm 3.54	13.89 \pm 4.61	10.99 \pm 3.39	14.08 \pm 5.22
F flexion left shoulder	17.69 \pm 4.71	17.80 \pm 6.73	12.19 \pm 3.97	15.97 \pm 5.65
F flexion left hip	17.40 \pm 5.07	21.93 \pm 7.63	13.69 \pm 3.25	16.19 \pm 6.49
F flexion left knee	10.05 \pm 2.44	11.53 \pm 4.81	9.09 \pm 3.11	11.12 \pm 5.03
F flexion body	30.11 \pm 9.63	38.31 \pm 11.65	18.00 \pm 4.27	30.18 \pm 12.82

Table 3

Maximum isometric voluntary strength of the sample of Force extension (N).

	Gymnasts		Non Gymnasts	
	Measurement 1	Measurement 2	Measurement 1	Measurement 2
F extension right elbow	13.92 ± 4.37	13.27 ± 5.20	9.05 ± 2.19	10.36 ± 3.82
F extension right shoulder	25.74 ± 6.55	23.87 ± 8.41	16.41 ± 5.15	20.39 ± 8.22
F extension right hip	45.34 ± 13.95	44.44 ± 17.86	30.84 ± 7.91	41.00 ± 16.67
F extension right knee	25.17 ± 9.48	25.59 ± 12.61	19.29 ± 7.27	25.82 ± 13.98
F extension left elbow	12.24 ± 3.13	10.84 ± 4.33	9.12 ± 3.02	10.84 ± 4.33
F extension left shoulder	25.47 ± 6.34	22.72 ± 8.95	16.30 ± 4.43	19.46 ± 8.22
F extension left hip	43.84 ± 13.54	40.07 ± 16.98	28.49 ± 7.81	39.04 ± 17.92
F extension left knee	22.57 ± 7.47	28.25 ± 11.56	20.41 ± 8.36	27.28 ± 12.98
F extension body	58.81 ± 20.83	86.01 ± 24.83	47.08 ± 13.14	54.25 ± 22.68

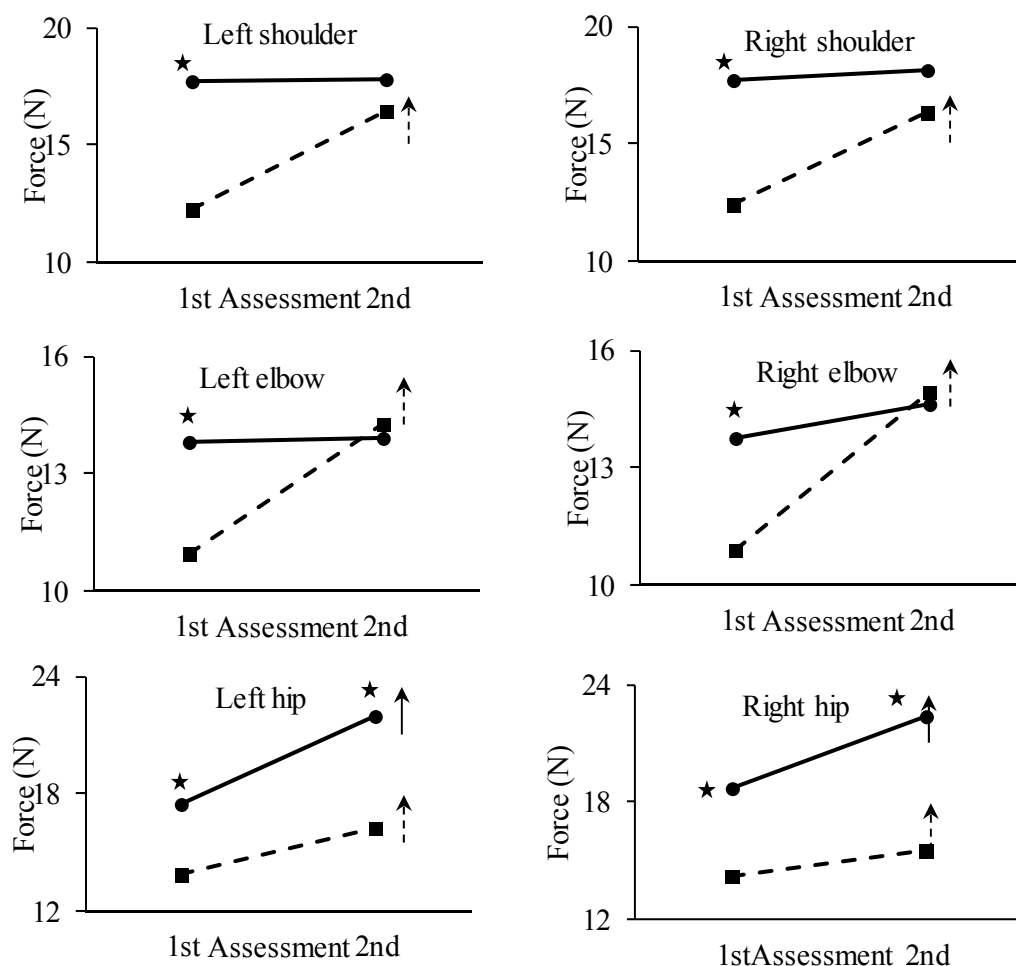

Figure 1. Force flexion mean values of different joints for the gymnasts (continuous lines) and non-gymnasts (dotted lines) groups at the two assessments. Statistically significant differences at the 0.05 level between the two groups at each assessment are denoted by asterisks. Statistically significant differences at the 0.05 level between the two assessments for each group are denoted by arrows.

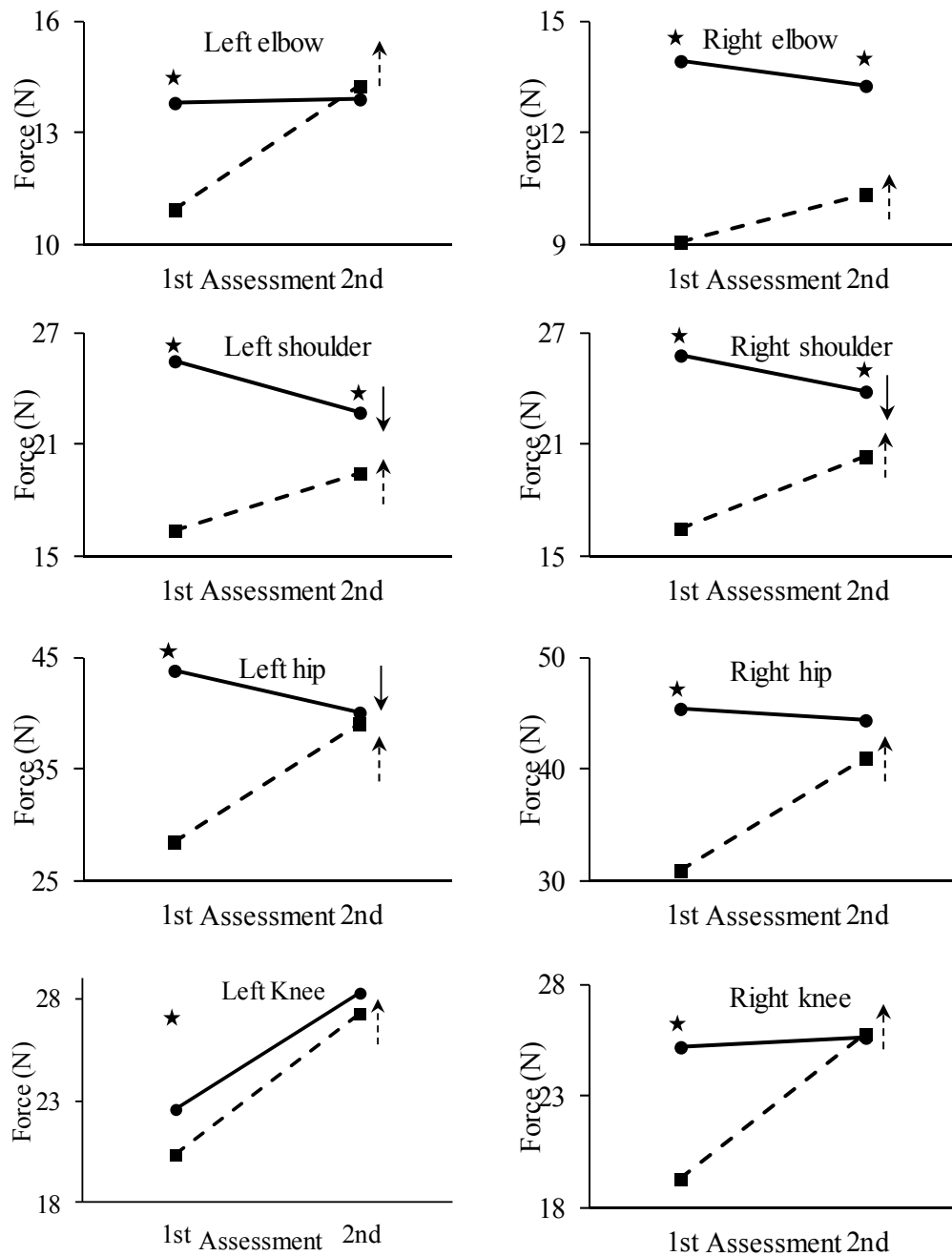

Figure 2. Force extension mean values of different joints for the gymnasts (continuous lines) and non-gymnasts (dotted lines) groups at the two assessments. Statistically significant differences at the 0.05 level between the two groups at each assessment are denoted by asterisks. Statistically significant differences at the 0.05 level between the two assessments for each group are denoted by arrows.

The 2 x 2 MANOVA revealed significant interaction between group (gymnasts and non gymnasts) and measurement (1st and 2nd assessment) with respect to the force flexion of the right side of elbow, shoulder, hip, and knee joints ($F=8.103$, $p=.000$, $\eta^2=.928$). The univariate post hoc 2 x 2 ANOVA's revealed that the interaction was attributed to the a) elbow ($F=21.621$, $p=.000$, $\eta^2=.144$), and b) shoulder ($F=16.589$, $p=.000$, $\eta^2=.114$) joints, respectively. The t-parameter estimates were significant for the first assessment a) for the elbow ($t=3.859$, $p=.000$), and b) for shoulder ($t=5.590$, $p=.000$). Finally, for the hip joint, significance was evident for both the first ($t=5.157$, $p=.000$) and second assessments ($t=5.274$, $p=.000$) (figure 1). With respect to the force flexion of the left side of elbow, shoulder, hip, and knee joints, the 2 x 2 MANOVA revealed significant interaction $F=11.114$, $p=.000$, $\eta^2=.261$). The univariate post hoc 2 x 2 ANOVA's revealed that the interaction was attributed to the a) elbow ($F=21.838$, $p=.000$, $\eta^2=.145$), b) shoulder ($F=25.837$, $p=.000$, $\eta^2=.167$) and c) hip ($F=4.159$, $p=.043$, $\eta^2=.031$) joints, respectively. The t-parameter estimates were significant for the first assessment for a) elbow ($t=4.745$, $p=.000$) and b) for the shoulder ($t=7.275$, $p=.000$). Finally, for the hip joint, significance was evident for both the first ($t=4.774$, $p=.000$) and second assessments ($t=4.642$, $p=.000$). The above findings may be found in figure 1.

The means scores of maximum isometric voluntary strength of Force extension in various joints are presented in table 3. It was mentioned that in majority of variables the training had a negative effect in Force extension on Gymnasts. On the contrary an increment was appeared in all examined variables on Force extension in both sides.

With respect to the force extension of the right side the 2 x 2 MANOVA revealed significant interaction ($F=9.980$, $p=.000$, $\eta^2=.241$). The univariate post hoc 2 x 2 ANOVA's revealed that the interaction was

attributed to the a) elbow ($F=11.390$, $p=.001$, $\eta^2=.081$), b) shoulder ($F=36.128$, $p=.000$, $\eta^2=.219$), c) hip ($F=24.614$, $p=.000$, $\eta^2=.160$) and d) knee ($F=14.863$, $p=.000$, $\eta^2=.103$) joints, respectively. The t-parameter estimates were significant for the first ($t=8.454$, $p=.000$) and the second assessment ($t=3.514$, $p=.001$) for the elbow, and for the shoulder ($t=9.029$, $p=.000$ and $t=2.047$, $p=.043$ for the first and second assessment, respectively). However, significance was evident only for the first assessment a) for the hip ($t=7.254$, $p=.000$) and b) for the knee ($t=4.033$, $p=.000$) (figure 2). With respect to the force extension of the left side of elbow, shoulder, hip, and knee joints, the 2 x 2 MANOVA revealed significant interaction ($F=11.219$, $p=.000$, $\eta^2=.263$). The univariate post hoc 2 x 2 ANOVA's revealed that the interaction was attributed to the a) elbow ($F=10.885$, $p=.001$, $\eta^2=.078$), b) shoulder ($F=25.380$, $p=.000$, $\eta^2=.164$) and c) hip ($F=38.569$, $p=.000$, $\eta^2=.230$). The t-parameter estimates were significant for the first assessment a) for the elbow joint, ($t=5.758$, $p=.000$), b) for the shoulder ($t=9.533$, $p=.000$), and c) for the hip joint, ($t=7.977$, $p=.000$). Finally, for the knee joint, significance was not evident for the first ($t=1.409$, $p=.161$) and the second assessments ($t=.192$, $p=.848$). The above findings may be found in figure 2.

DISCUSSION

The purpose of this study was to examine the effects of training on maximum voluntary isometric strength (MVIS) in young male gymnasts and to compare these results with the corresponding of previous annual training period. The applied strength training program in AG between two annual periods has a positive effect on maximum voluntary isometric strength (MVIS) of young male gymnasts. The results showed significant differences between gymnasts and non-gymnasts ($p<.05$). In addition, significant differences were found in male gymnasts between two evaluation measurements ($p<.05$). A variety of training

strategies (modalities) including mainly exercises with body weight in various apparatus, free weights as well as different combinations of sets and repetitions (amount of volume) has lead to produce (provide) an increment of MVIS and an adequate stimulus for strength development in young male gymnasts. Results of our study verify previous data which support a positive strength training effect in pre-adolescents athletes (Benjamin, & Glow, 2003; Falk, & Tenenbaum, 1996; Faigenbaum, 2007) and reject the old notion that strength training is ineffective for children (Faigenbaum et al, 1996; Stone et al, 2004). Also, our results support the notion that an improvement in muscle strength cannot be achieved by intensive performance of the event itself (Bührlé, & Werner, 1984), but an adequate level of strength for advanced gymnastics can be achieved by participating in a progressive resistance training program (Bernhardt et al, 2001; Faigenbaum et al, 2001; Fukunaga, Funato, & Ikegawa, 1992). Gymnastics training requires the use of a considerable degree of upper arm limb's strength during performance on supporting and hangings apparatus (side horse, rings, parallel bars and fix bar) as well a considerable degree of lower limb's strength during performance on floor exercises and vaulting horse. The improvement of strength may allow gymnasts to perform more skilfully by increasing the jumps, leaps and pressure in various routines.

Special strength for gymnastics training must answer the demands of gymnastics. The principle of specificity implies that the exercise used in training should be similar to the exercises that must be performed in the competition routine. This special training is necessary to develop the strength and power in young gymnasts, which is the core for correct technical performance of gymnastics routines. The statistical differences between gymnasts and non-gymnasts in MVIC should be attributed to the long-term training adaptations. Heavy resistance strength training performed by male young gymnasts (in daily) may have

produced long term training-induced increases in the MV neural drive to the muscles associated of MV (Faigenbaum et al, 1996). The important role of isometric strength has well demonstrated in various sports (McGuigan, Winchester, & Erickson, 2006; Stone et al, 2004; 2005) and provides a good indication of an athletic dynamic performance during MVIC testing. Maximum strength appears to be a significant (major) factor influencing performance in a variety of different sports (Stone et al, 2004). Douda et al (2002) point out that long-term training affects the muscle mass of the upper limbs in artistic gymnasts, due to the dynamic structure of supporting exercises.

AG is a sport where the production of large forces over relative long time periods would appear to be readily improved by strength training. MVIC is a simple way to evaluate and compare muscle strength in young male gymnasts because it is not confounded by issues of movement velocity and changing joint angle. It has been strongly influence the relationships that are observed with dynamic tasks (Haff et al, 1997). Future researchers may examine the effect of isometric strength training on the knee flexion and extension, of different joints of competitive gymnasts, at different age groups, in a variety of competitive levels, etc.

Results of the study showed that strength training program in AG between two annual periods has a positive effect on MVIS of young male gymnasts. These findings suggest that it could be useful to improve isometric strength in young male gymnasts' as this improvement facilitate the execution of technical exercises that gymnasts incorporate in their gymnastic routines. Moreover, this strength training program is useful not only for coaches designing the training programs for gymnasts but also for the prevention of injuries. Thus, gymnastics sports with high injury rates may benefit from strength training. Furthermore, a potential practical application of our findings is that the MVIC can be used by trainers to provide important

information about MVIC to their gymnasts of same aged. An improvement of muscular voluntary isometric strength can be achieved through training program in young male gymnasts. It will be useful in order to overcome the high level of loadings during static elements in various apparatus.

CONCLUSIONS

This study supports that training program for strength development in male gymnasts resulted in increase in MVIS. The MVIS provides an efficient method for assessing isometric strength in young male gymnasts, differentiating gymnasts and non gymnasts. Strength is required for movements, and the level of strength determines, in part, the ease and effectiveness of performance in many day-to-day sport activities. Increasing size and strength of skeletal muscle is an important feature of childhood and adolescence. Strength gains are indeed possible when children's are placed on a proper progressive resistive exercise program. These findings must be taken into consideration by trainers to order an effective training program and improve the existent level of strength.

ACKNOWLEDGEMENT

We would like to thank participants of the study for volunteering their time. We also thank trainers and clubs directors for providing gymnastics clubs that were used in this study.

REFERENCES

American College of Sports Medicine (2000). *ACSM's Guidelines for Exercise Testing and Prescription (6th ed.)*. Baltimore: Lippincott, Williams & Wilkins.

Bassa, H., Kotzamanidis, C., Siatras, T., Mameletzi, D., & Skoufas, D. (2002). Coactivation of knee muscle during isokinetic concentric and eccentric knee extensions and flexions in prepubertal

gymnasts. *Isokinetics and Exercise Science*, 10, 137-144.

Benjamin, H.J., & Glow, K.M. (2003). Strength training for children and adolescents. What can physicians recommend? *The Physician Sports Med*, 31(9), 21-28.

Bernhardt, D.T., Gomez, J., Johnson, M.D., Martin, T.J., Rowland, T.W., Small, E, Bar-Or, O. (2001). Strength training by children and adolescents. *Pediatrics*, 107, 1470-1472.

Bührle, M., & Werner, E. (1984). Das Muskelquerschnittstraining der Bodybuilder Themuscle hypertrophy training of the body builder. *Leistungssport*, 3, 5-9.

Daly, R.M., Rich, P.A., & Bass, S. (1999). Effects of High-Impact Exercise on Ultrasonic and Biochemical Indices of Skeletal Status: A Prospective Study in Young Male Gymnasts. *Journal of Bone and Mineral research*, 14(7), 1222-1230.

Demura, S., Yamaji, S., Nagasawa, Y., & Minami, M. (2000). Examining of force production properties during static explosive grip based on force-time curve parameters. *Perceptual and Motor Skill*, 67, 1209-1220.

Docherty, D., Wender, H.A., Collis, M.L., & Quinney, H.A. (1987). The effects of variable resistance training on strength development in prepubertal boys. *Journal of Human Movement Studies*, 13, 377-382.

Douda, H., Laparidis, K., & Tokmakidis, S.P. (2002). Long-term training induces specific adaptations on physique of rhythmic sports and female artistic gymnasts. *European Journal of Sport Science*, 2(3), 1-14.

Dowthwaite, J.N., & Scerpella, T.A. (2009). Skeletal Geometry and Indices of Bone Strength in Artistic Gymnasts. *Journal of Musculoskeletal Neuronal Interact*, 9(4), 198-214.

Era, P., Lyyra, A.L., Viitasalo, J.T., & Hikkinen, E. (1992). Determinants of isometric muscle strength in men of different ages. *European Journal of Sport Science*, 64, 84-91.

Faigenbaum, A.D. (2007). State of the art Reviews: Resistance training for children

and adolescents. *American Journal of Lifestyle Medicine*, 1(3), 190-200.

Faigenbaum, A.D., Kraemer, W., Cahill, B., & Roberts, S. (1996). Youth resistance training: Position statement paper and literature review. *Strength and Conditioning Journal*, 18(6), 62-75.

Faigenbaum, A.D., Westcott, W.L., Loud, R.L., Long, C. (1999). The Effects of Different Resistance Training Protocols on Muscular Strength and Endurance Development in Children. *Pediatrics*, 104 (1). URL: <http://www.pediatrics.org/cgi/content/full/104/1/e5>.

Faigenbaum, A.D., Loud, R.L., O'Connell, J., Glover, S., O'Connell, J., & Westcott, W.L. (2001). Effects of different resistance training protocols on upper-body strength and endurance development in children. *Journal of Strength and Conditioning Research*, 15(4), 459-465.

Falk, B., & Tenenbaum, G. (1996). The effectiveness of resistance training in children: a meta-analysis. *Sports Medicine*, 22(3), 176-186.

Farana, R., Jandacka, D., Uchytel, J., Zahradnik, D., & Irwin, G. (2014). Musculoskeletal loading during the round-off in female gymnastics: the effect of hand position. *Sports Biomechanics*, 13(2), 123-134.

Farrell, M., & Richards, J.G. (1986). Analysis of the reliability and validity of the kinetic communicator exercise device. *Medicine and Science in Sport and Exercise*, 18, 44-49.

Fukunaga, T., Funato, K., & Ikegawa, S. (1992). The effects of resistance training on muscle area and strength in prepubescent age. *The Annals of physiological anthropology*, 11, 357-364.

Haff, G.G., Stone, M.H., O'Bryant, H., Harman, E., Dinan, C., Johnson, R., & Han, K. (1997). Force-time dependent characteristics of dynamic and isometric muscle action. *Journal of Strength and Conditioning Research*, 11, 269-272.

Hakkinen, K., & Komi, P.V. (1986). Training induced changes in neuromuscular performance under voluntary and reflex

conditions. *European Journal of Applied Physiology*, 55, 147-155.

Hickson, R.C., Hidaka, K., & Foster, C. (1994). Skeletal muscle fiber type, resistance training, and strength-related performance. *Medicine and Science in Sport and Exercise*, 26 (5), 593-598.

Hickson, R.C., Dvorak, B.A., Gorostiaga, E.M., Kurowski, T.T., & Foster, C. (1998). Potential for strength and endurance training to amplify endurance performance. *Journal of Applied Physiology*, 65, 2285-2290.

Kanehisa, H., & Miyashita, M. (1983). Effect of isometric and Isokinetic Muscle Training on Static Strength and Dynamic Power. *European Journal of Applied Physiology*, 50(3), 365-371.

Maffulli, N., King, J.B., & Helms, P. (1994). Training in elite young athletes (the training of young athletes (TOYA) study): injuries, flexibility and isometric strength. *British Journal of Sport Medicine*, 28(2), 123-136.

McGuigan, M.R., Winchester, J.B., & Erickson, T. (2006). The importance of isometric maximum strength in college wrestlers. *Journal of Sport Science and Medicine*, 1,5(CSSI), 108-113.

McNitt-Gray, J.L. (1991). Kinematics and impulse characteristics of drop landings from three heights. *International Journal of Sport Biomechanics*, 7, 201-224.

Mellos, V., Dallas, G., Kirialanis, P., Fiorilli, J., & Di Cagno, A. (2013). Comparison between physical conditioning status and improvement in artistic gymnasts and non-athletes peers. *Science of Gymnastics Journal*, 6, 33-43.

Naughton, G., Farpour-Lambert, N.J., Carlson, J., Bradney, M., & Van Praagh, E. (2000). Physiological Issues Surrounding the Performance of Adolescent Athletes. *Sport Medicine*, 30(5), 309-325.

Osguven, H.N., & Berne, N. (1988). An experimental and analytical study of impact forces during human jumping. *Journal of Biomechanics*, 21(12), 1061-1066.

Ozmun, J.C., Mikesky, A.E., Surbukg, P.R. (1994). Neuromuscular adaptations

following prepubescent strength training. *Medicine and Science in Sport and Exercise*, 26, 510-514.

Parker, D.F., Round, J.M., Sacco, P., & Jones, D.A. (1990). A cross-sectional survey of upper and lower limb strength in boys and girls during childhood and adolescence. *Annals of Human Biology*, 17, 199-211.

Ramsay, J.A., Blimkie, C.J.R., Smith, K., Garner, S., MacDougall, J.D., & Sale, D.G. (1990). Strength training effects in prepubescent boys. *Medicine and Science in Sport and Exercise*, 22(5): 605-614.

Sadres, E., Eliakim, A., Constantini, N., Lidor, R., & Falk, B. (2001). The Effect of Long-Term Resistance Training on Anthropometric Measures, Muscle Strength, and Self Concept in Pre-Pubertal Boys. *Pediatric Exercise Science*, 13, 357-372.

Sewall, L., & Micheli, L. (1986). Strength training for children. *Journal of Pediatric Orthopaedics*, 6, 143-146.

Stone, M.H., Sands, W.A., Carlock, J., Callan, S., Diokie, D., Daigle, K., & Hartman, M. (2004). The importance of isometric maximum strength and peak rate-of-force development in sprint cycling. *Journal of Strength and Conditioning Research*, 18, 878-884.

Stone, M.H., Sands, W.A., Pierce, K.C., Carlock, J., Cardinale, M., & Newton, R.U. (2005). Relationship of maximum strength to weightlifting performance. *Medicine and Science in Sport and Exercise*, 37, 1037-1043.

Surakka, J., Virtanen, A., Aunola, S., Maentaka, K., & Pekkarinen, H. (2005). Reliability of knee muscle strength and fatigue measurements. *Biology of Sport*, 22(4), 301-313.

Tood, G., German, R.B., & Gandevia, S.C. (2004). Measurement and reproducibility of strength and voluntary activation of lower-limb muscles. *Muscle Nerve*, 29, 834-842.

Weltman, A., Janney, C., Rians, C.B., Strand, K., Berg, B., Teppitt, S., Katch, F.I. (1986). The effect of hydraulic resistance strength training in pre-pubertal

males. *Medicine and Science in Sport and Exercise*, 18, 629-638.

Corresponding author:

George Dallas
National and Kapodistrian University of Athens
Physical Education and Sport Science
41, Ethnikis Antistaseos
Dafne, Athens 17237
Greece
phone: 0030 210 66 43 704
fax: 0030 693 65 92 665
e-mail: gdallas@phed.uoa.gr

KINEMATIC ANALYSIS OF THE NEW ELEMENT “DIMIC” AND ITS COMPARISON WITH “BILOZERCHEV” ON PARALLEL BARS

Edvard Kolar¹, Sebastijan Piletič², Klemen Bedenik², Mitija Samardžija
Pavletič², Stanko Štuhec³, Saša Veličković⁴

¹University of Primorska, Science and Research Centre, Institute of Kinesiology Research,
Koper, Slovenia

²Gymnastics Federation of Slovenia

³University of Ljubljana, Faculty of Sport, Ljubljana, Slovenia

⁴University of Niš, Faculty of Sport and Physical Education, Niš, Serbia

Original article

Abstract

Development and recognition of new gymnastics element is subjected to the evaluation of difficulty and structural complexity of the skill. The authority over the procedure lies with the Technical Committee of International Gymnastics Federation (FIG TC) and thus the classification of an element is a result of the subjective perception of its members. The present article pursued two goals. First, a method of biomechanical modelling was used to present a new gymnastics element “Dimic” on parallel bars. Second, as the element “Dimic” was evaluated with the same difficulty and placed in an identical position as “Bilozherchev” element in the Code of Points tables, the accuracy of the evaluation was tested by comparing kinematical characteristics of both elements. Measured subject was a gymnast AD, who for the purpose of the study performed both elements. Kinematic analysis was performed with the help of APAS 3-D video motion analysis system, using a model with 17 points and 15 segments. A comparison of kinematic characteristics (movement of body centre of gravity and the supporting left hand, the amount of rotation around the longitudinal axis) revealed significant differences in a non-support phase of elements both in structural characteristics and the difficulty of the execution of the skills. It can be concluded that the placement of the “Dimic” skill in the Code of Points seems incorrect. A method used in the study could in future be used in order to more adequately place new skills into the Code of Points.

Keywords: *new skills, evaluation, Code of Points.*

INTRODUCTION

Based on the structural complexity of movements (Matveev, 1977) in individual sports disciplines, gymnastics has been categorised into a group of conventional sports, which are characterized with aesthetic and physically determined acyclic sets of structures that can be carried out either in standard or varied external

conditions. Conventional character of artistic gymnastics defines the process of managing sportsmen in gymnastics. Conventionality of sports discipline implies that all motion/movements must be performed in the context of a particular motoric model (prescribed by the experts - convention), which could be called the *ideal*

model of movement (IMM). IMM is determined with the biomechanical model of movement and is prescribed in the regulations (Code of Points) for the assessment by the International Gymnastics Federation (FIG). Evaluation of the athletes in conventional sports is carried out by judges evaluating the performance of motion content, which athletes demonstrate in competitions. The criterion of evaluation is based on the comparison between the IMM and actually performed movement by each gymnast. Therefore, the number and the complexity of the elements, which the gymnast masters and is able to successfully (in accordance with regulations) perform at the competitions, primarily define success in conventional sports (Kolar, Samardžija-Pavletič, & Veličković, 2015).

Elements in the Code of Points (FIG, 2013) are assigned different difficulty according to the complexity of their movement. In sports training theory, term motor structure technique (element) represents a certain form of motion, which is standardized and identified by name. Motor technique and IMM in the performance of gymnastics elements are determined with the biomechanical model of movement and its kinematic and dynamic characteristics (Kolar, Piletič, & Veličković, 2005, p. 12-13). Biomechanical modelling is used to reveal relevant physical - biomechanical model for the selected element or movement in order to describe the movement and define the technique of a particular element with physical values. The physical description of motion is required in arbitrarily selected data in order to predict the movement with numerical values of its quantity, such as velocity, acceleration, force, etc.

Biomechanical models of the elements can be used for the different purposes. When used only for the sake of analysis and description of motion, biomechanical model needs to be properly interpreted and described with calculated kinematic and dynamic parameters (Davis, 2005; Heng, 2007; Linge, Hallingstad, & Solberg, 2006; Manoni, De Leva, Carvelli, & Mallozzi,

1992a; 1992b; Marinšek, Kolar, Piletič, & Kugovnik, 2006; Prassas, 1994; Prassas & Ariel, 2005; Tsuchiya, Murata, & Fukunaga, 2004; Veličković et al., 2011). Further use of such biomechanical model is in the planning of methodical procedures or in the planning of physical preparation for analysed movement (Čuk, 1996; Veličković, 2005; Veličković et al., 2013). In the evaluation of methodical procedures, it is necessary to adequately explain each methodical step, its adequacy and advantages over other steps, and the reasons for skipping individual methodical steps and shortening the methodical process (Kolar, Andlovic-Kolar, & Štuhec, 2002). Identification of errors during movements or detection of inconsistency in the performance of the elements requires a large number of repetitions of an element (Gervais & Dunn, 2003; Hiley, Wangler, & Predescu, 2009; Kolar, Piletič, Kugovnik, Andlovic-Kolar, & Štuhec, 2005; Prassas, Ostarelo, & Inoraj, 2004; Veličković, 2005). Introduction of new elements requires mathematical modelling of already accomplished movements, when a different body position is foreseen in the movement performance (e.g. straight instead of tucked position) or when rotation around the longitudinal or transverse axes is added to already accomplished movements (Čuk, 1996; Čuk, Atiković, & Tabaković, 2009).

Biomechanical model of skills can also be used to compare skills and find differences or similarities in the technique and complexity of elements (Čuk, 1995; Manoni, De Leva, Carvelli, & Mallozzi, 1992b; Veličković et al., 2005). Such comparisons should also be used when setting a difficulty of skills and their placement in the FIG Code of Points, particularly in cases of new skills that have previously not been included in the tables. The study aims to fulfil two goals. The first is a presentation of a new gymnastics element "Dimic" on parallel bars. The second is to use kinematic characteristics of the skill for testing the correctness of the decision made by the FIG Men's Technical Committee (MTC) about the difficulty of

the skill and its placement in the Code of Points.

Element "Dimic" on parallel bars has been performed for the first time on September 2 2011 at the World Cup series competition in Ghent (qualifications). Evaluation of an element from the FIG MTC was following (FIG, 2013):

- element was placed in a *group I of elements on parallel bars*,
- element was categorised as a *D difficulty element*,
- element was placed in *box I.10 together with Bilozerchev element*.

As "Dimic" and "Bilozerchev" were both placed in box I.10 in the Code of Points (see Figure 1), consequently gymnasts are not allowed to perform both elements in the routine. Nevertheless, the following comparison of kinematical parameters will reveal that the elements are different in their movement structure.

METHODS

The *sample* is represented by A.D (age 27 years; body height 1.72 m; body mass 64 kg) a Slovenian men's artistic gymnastics national team member, a multiple medal winner on parallel bars at the World Cup competitions. Measured participant has performed both elements in competitive exercise (Bilozerchev between 2004 until 2011; Dimic from 2011 onwards).

Measurements and data analysis were carried out in standard method, as prescribed by 3D Ariel Performance Analysis System (APAS). As part of the kinematic analysis, digitization of the 15-segment model (Dempster, 1955) of competitor was conducted. Measurements were performed on 07/09/2011 in Ljubljana (SLO). Measured participant performed both elements in training. Both elements were recorded with the help of two synchronized DVCAM - Sony - SR - 300 PK cameras, with a 50Hz framerate. Before recording, and for precise space calibration, two reference frames were videotaped ($1m^3$), which were positioned in the middle of the parallel bars. Centre point of the

coordination system was at the centre between the bars (Figure 5). For research purposes, successful (without technical errors) execution of each element was evaluated by three international judges and selected for further analysis.

For the presentation of new gymnastic skill "Dimic", a model by Smolevskij (1992) was used to present a theoretical biomechanical model of the element.

Sample of variables is represented with selected kinematical parameters (trajectories and angles), describing the most significant differences in the movement of both elements. For the purpose of the research, following parameters were calculated:

- path (trajectory) of the body centre gravity in z-axis (D_BCG_z_Dimic and D_BCG_z_Bilozerchev);
- path (trajectory) of the supporting arm in z-axis (D_L_wrist_z_Dimic and D_L_wrist_Bilozerchev);
- rotation of the hip joint around longitudinal axis (ROT_hips_Dimic and ROT_hips_Bilozerchev);
- rotation of the shoulder joint around longitudinal axis (ROT_shoulders_Dimic and ROT_shoulders_Bilozerchev)

Finally, velocity in horizontal (V_BCG_x_Dimic) and vertical (V_BCG_y_Dimic) axes in the element "Dimic" was calculated in order to appropriately present the new gymnastics skill.

RESULTS

Element "*Dimic*" on parallel bars is an element from group I, consisting of the *elements performed in or through support on both bars*. Movement in element "Dimic" can be described in two ways (Figure 2):

- as a "stutzkehr" forward with 1/4 turn to handstand sideways on 1 rail (Bilozerchev with 1/2 turn), or
- as a $\frac{3}{4}$ turn in forward swing in support with hop to opposite bar into handstand on one bar, facing out.

- According to the position of the gymnast in relation to the apparatus during the performance of movement (Smolevskij, 1992), “Dimic” skill can be divided into:
- support part (Figure 2; positions 1 to 7),
- non-support part (Figure 2; position 8) and
- support part on both hands on one rail (Figure 2; positions 9 and 10).

Support part of the skill is represented with a movement from the handstand to the high forward swing (see Figure 2; positions 1 – 7). Movement in this part of the skill can be approximated as a suppressed motion of a two-segment stiff body (Opavsky, 1971). In execution of the movement, the centre of gravity of a subsystem forearm-upper arm lies above the supporting area. Thus, the entire system is supported above the point of contact (grip) with the apparatus and acts as a supported pendulum. The centre of a second subsystem head-torso-legs acts as a suspended pendulum and lies below the shoulder axis, which represents a meeting point of both subsystems. A supporting area for the entire system is relatively small and as a result maintaining of balance in swing is difficult. In order to achieve swinging with large amplitudes, it is imperative that both mentioned subsystems are simultaneously coordinated in opposite directions (Marinšek, Kolar, Piletič, & Kugovnik, 2006, p. 40). This leads to oscillation of the body centre of gravity (BCG) as close as possible to the vertical line, which runs through the supporting area. Nevertheless, the execution of more difficult skills in support on parallel bars require oscillation of the BCG in forward and backward direction that is larger than allowed by the supporting area. Such deviations away from the supporting area allow the gymnast a better exploitation of swing that is required for the execution of the succeeding skill (Marinšek, Kolar, Piletič, & Kugovnik, 2006, p. 40). This is achieved with an intermuscular coordination of the entire system and the strength of arms and wrists, which enables a strong grip of

the bars and results in a dynamic balance of the entire system. Dynamic balance is a term, which describes keeping the BCG above the supporting area whilst the entire system (i.e., gymnast) is in motion (Kolar et al., 2005). The aim of dynamic balance is to achieve positions enabling most optimal execution of movement with only small adjustments. According to the criterion of the direction of force acting (Smolevskij, 1992), the supporting part of the skill can be divided into an accumulation phase (see Figure 2; positions 1 – 5) and work phase (see Figure 2; positions 6 – 7).

Accumulation phase is represented with a downward movement from the position of handstand to the position of lower vertical (see Figure 3; from $t=0.0s$ to $t=0.52s$). The characteristic of the accumulation phase is that the body moves in the same direction as the gravity acts, resulting in the positive acceleration of the body ($+\alpha$). In **work phase** the gymnast moves from lower vertical into forward upward swing, in the opposite direction to the gravity acting, which decelerates the body ($-\alpha$). According to this, gymnast should acquire the highest velocity at the point of transition from accumulation to the work phase. However, some authors have found that the movement of the BCG when swinging on parallel bars is similar to the yo-yo movement as seen when looking at the trajectory of BCG, which describes the U-path and not the circular path (Kolar, Andlovic-Kolar, & Štuhec, 2002; Mannoni et al. 1992a). The phenomenon could be explained with the elasticity of the parallel bars, acting on the gymnast according to the action-reaction principle and the oscillation of the shoulders (supported pendulum motion) (Kolar, Andlovic-Kolar, & Štuhec, 2002; Kolar et al., 2005). In the moment, when gymnast starts to move shoulders backward (when suspended pendulum crosses the horizontal position in the accumulation phase; Figure 2; position 4), BCG starts to move closer to the supporting area (angle in the shoulder joint (ϕ) is getting smaller). As a result, radial force (F_r) increases whilst the tangential

component of the force (F_t) decreases, whilst the force of gravity (F_g) is represented with a product of gymnast's mass and the acceleration due to gravity near the surface of Earth (9.8 m/s^2) (see equations 1a and 1b).

$$(a) \quad F_r = F_g \cdot \cos\phi$$

$$(b) \quad F_t = F_g \cdot \sin\phi$$

Increase of the radial force component results in the increase of the force acting on the surface (larger part of the body mass is above the supporting area). As the force acting on the parallel bars also increases, the bars bend due to their elasticity (Figure 2; position 5), which results in decreased vertical velocity and increased horizontal velocity of the BCG (see Figure 3; from $t=0.33\text{s}$ to $t=0.52\text{s}$). After the body passes the lowest point of the movement (see Figure 3; $t=0.52\text{s}$), gymnasts enters **work phase** and executes the movement from the lower vertical to the moment of release with supporting arm (see Figure 3; from $t=0.52\text{s}$ to $t=0.93\text{s}$). During this movement, the force acting on the parallel bars continues to increase for a short period (reaction principle) and thus helps the BCG with upward acceleration, transpiring in larger vertical and smaller horizontal velocity of the BCG (see Figure 3; from $t=0.52\text{s}$ to $t=0.72\text{s}$) (Marinšek et al., 2006; Marinšek & Kolar, 2007). Gymnasts achieves the highest vertical velocity (see Figure 3: $V_y = 2.96 \text{ m}\cdot\text{s}^{-1}$; $t = 0.68 \text{ s}$) just prior to the release with the take-off arm (in this case right arm) and transition to the one-arm support (i.e., left arm) (see Figure 3: $t = 0.72\text{s}$).

Eccentric push sideways (in Z-axis) with a take-off arm and the leaning on the supporting arm results in the transverse axis of the gymnast moving away from the vector of angular momentum. The direction of the latter allows the body of the gymnast to commence rotation around the longitudinal axis (Yeadon, 1999), which is enabled by beginning the turn in a contact-way (see Figure 2; positions 6). The turn around the longitudinal axis is initiated with the turn of the hips in the direction of the turn (see Figure 4; $t=0.66\text{s}$) and the turn of

the shoulders, which first move into the opposite direction (see Figure 4; from $t=0.66\text{s}$ to $t=0.81\text{s}$) and then in the same direction as the body (see Figure 4; from $t=0.82\text{s}$). Movement in this part of the skill can be described as the combination of translation and rotation around the longitudinal axis. Gymnast uses accumulated energy in order to execute desired movement on the supporting arm to the point of high forward swing (see Figure 2; position 7), whilst performing the turn with the hips for 117.9° and shoulders for 87.2° around the longitudinal axis (see Figure 4; from $t=0.72\text{s}$ to $t=0.93\text{s}$).

Movement on the supporting arm in the work phase ends when the gymnast performs an eccentric take-off from the parallel bars also with the supporting arm (see Figure 2; positions 7). At this time, gymnast begins a **non-support part** or **execution phase** (see Figure 3 and 4; from $t=0.93\text{s}$ to $t=1.31\text{s}$) of the element. The direction of the eccentric take-off with supporting arm in the Z-axis is opposite to the push from the take-off arm in the moment of the transition onto supporting arm. This leads to the body moving in Z-axis into opposite direction to the supporting arm (see Figure 2; positions 7 - 9). The gymnast uses accumulated energy from the support part of the skill in order to execute desired movement in the non-support part of the skill. Linear momentum acquired in the support part of the skill will determine if the gymnast will be able to end the skill in the desired final position, whereas the angular momentum mostly defines whether the gymnast will be able to perform required rotation around the longitudinal axis in the non-support part (execution phase) of the skill. In the execution part of the skill a gymnast performs turn with the hips for 94.6° and with shoulders for 162.1° around the longitudinal axis (see Figure 4; from $t=0.93\text{s}$ to $t=1.31\text{s}$). The movement in the execution phase can be described with the Principle of conservation of angular momentum (Prassas, 1999). Angular momentum is a vector product of linear momentum (G) and the lever (r) or the

product of angular velocity and the moment of inertia of the body (J), which is equal to the product of the lever squared (r^2) and mass (m) (see equations 2a, b and c):

$$(a) \quad \Gamma = G r = (mv)r$$

$$(b) \quad \Gamma = J\omega = (M/\alpha)\omega$$

$$(c) \quad J = mr^2$$

A gymnast can use the work of muscles in order to change the moment of inertia of the system. By reducing or increasing the distance of the take-off arm (with the supporting arm in extended position - see Figure 2; position 8) from the axis of rotation, the gymnast also reduces or increases body moment of inertia and consequently increases or reduces the angular velocity. This enables a gymnast to control angular velocity in the execution of turning around the longitudinal axis in non-support part and precise ending of the execution phase of the skill (Marinšek et al., 2006; Yeadon, 1999).

Non-support part of the skill ends at the moment when a gymnast grabs the opposite rail with the take-off arm, finishing in a **support part with both hands on one rail** (see Figure 2; positions 9 and 10). Due to the acting of forces, the support part with both hands on one rail can be called **amortisation phase** (see Figure 4; from $t=1.31s$ to $t=1.52s$), when a gymnast finishes the rotation of the body around the longitudinal axis into support position (see Figure 4; hips for 35.2° and shoulders for 21.1°). Similarly to the work phase, in the amortisation phase gravity acts in the opposite direction to the muscular activity. When a gymnast lands in handstand, the impact of torques of all external forces onto the body of the gymnast has to be equal to the angular momentum in non-support part, allowing the gymnast to finish the skill in still position (Kolar & Piletič, 2005, p. 23).

A comparison of elements "Dimic" and "Bilozerchev" on parallel bars reveals some similarities between the skills. Both elements start in the same position (handstand in support on both bars) and continue their movement in the same direction into forward swing in support.

They are both performed on the same supporting arm (left arm).

Both elements end in the same final position (handstand in support sideways on one bar facing out); nevertheless, an important difference in these positions can be noticed. Final position of "Dimic" skill is on the opposite bar from the supporting arm in handstand facing out while the final position of "Bilozerchev" skill is on the same bar as the supporting arm in handstand facing out. Identified difference indicates that the body centre gravity and other body parts in execution phase of the element "Dimic" travel on a longer path in z-axis (deviation from centre of parallel bars – see Figure 6: the difference in the position of the BCG is $0.706m$ and the difference in the position of the supporting left arm is $0.592m$) in comparison to the element "Bilozerchev". During the "Dimic" element – from the beginning of work phase on both hands ($t=0.52s$) to the end of amortization phase ($t=1.52s$) – the BCG travelled $0.440m$, which compared to the element "Bilozerchev" (travel of the BCG is $0.259m$) reveals a difference of $0.181m$ (69.9%). Similar results have been noticed for the supporting left arm, which from the beginning of work phase on support hand ($t=0.72s$) to the end of amortization phase ($t=1.52s$) travelled $0.595m$ in element "Dimic" and only $0.003m$ in element "Bilozerchev", showing a difference of $0.592m$.

Additionally, important difference between the two elements was revealed in the amount of rotation around the longitudinal body axis (y-axis) in the execution phase of each element. In the element "Dimic", body rotates for approximately $\frac{3}{4}$ of a turn (see Figure 7, 269.1° hips and 276.3° shoulders) around the longitudinal axis, whereas in the element "Bilozerchev" body rotates only for around $\frac{1}{4}$ of a turn (Figure 7, 87.6° hips and 88.2° shoulders) around the longitudinal axis. Difference between the elements in the amount of body rotation around the longitudinal axis is more than $\frac{1}{2}$ turn or

207.2% in hips rotation and 213.3% in shoulder rotation (see Figure 7).

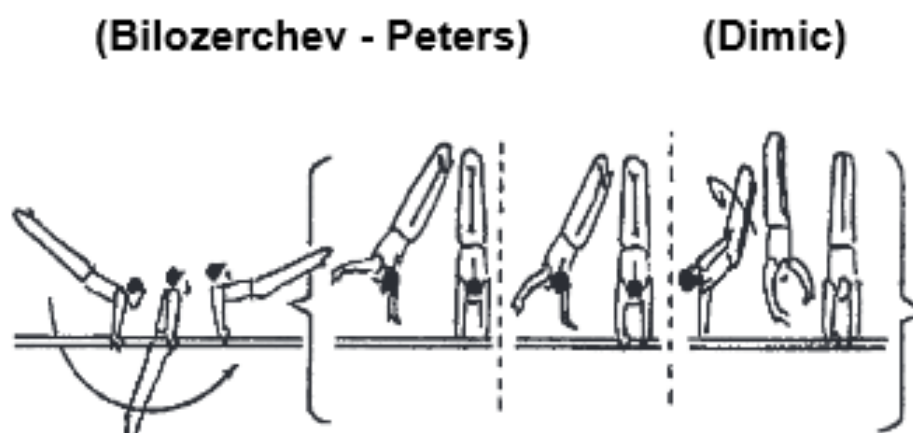

Figure 1. Box I.10 in Men's artistic gymnastics Code of Points (FIG, 2013).

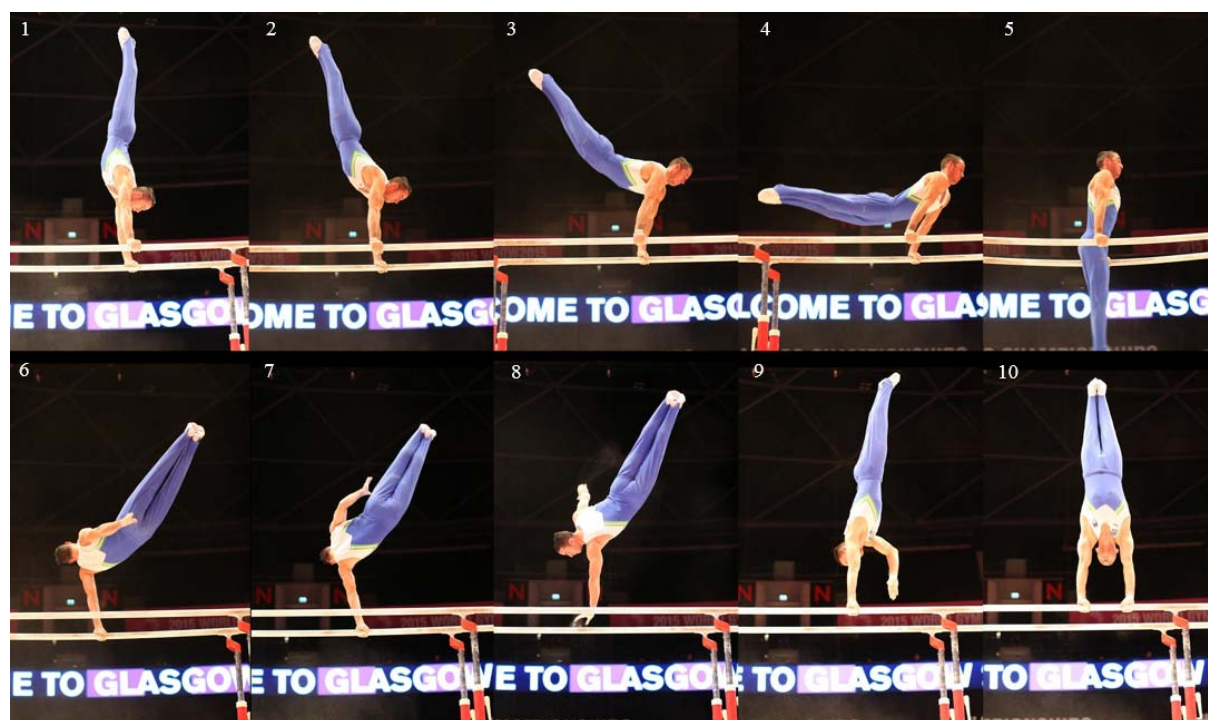

Figure 2. Element "Dimic" on parallel bars.

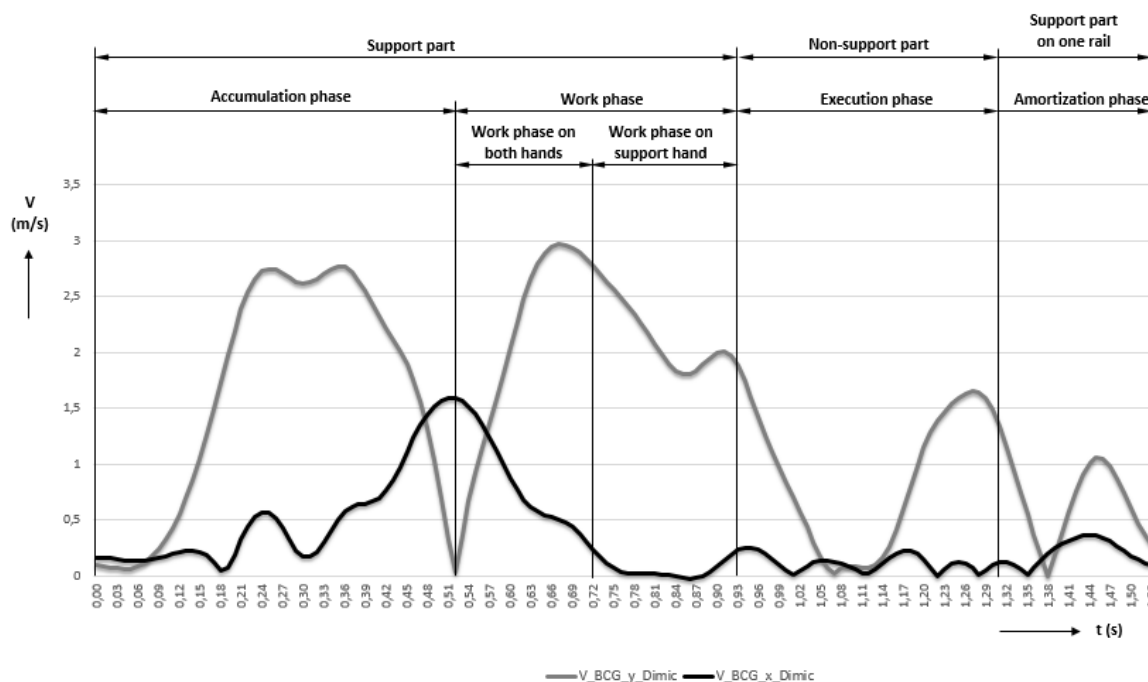

Figure 3. Velocity of the body centre of gravity (BCG) in vertical and horizontal axes in element “Dimic” and description of different phases of an element according to the Smolevskij’s (1992) model.

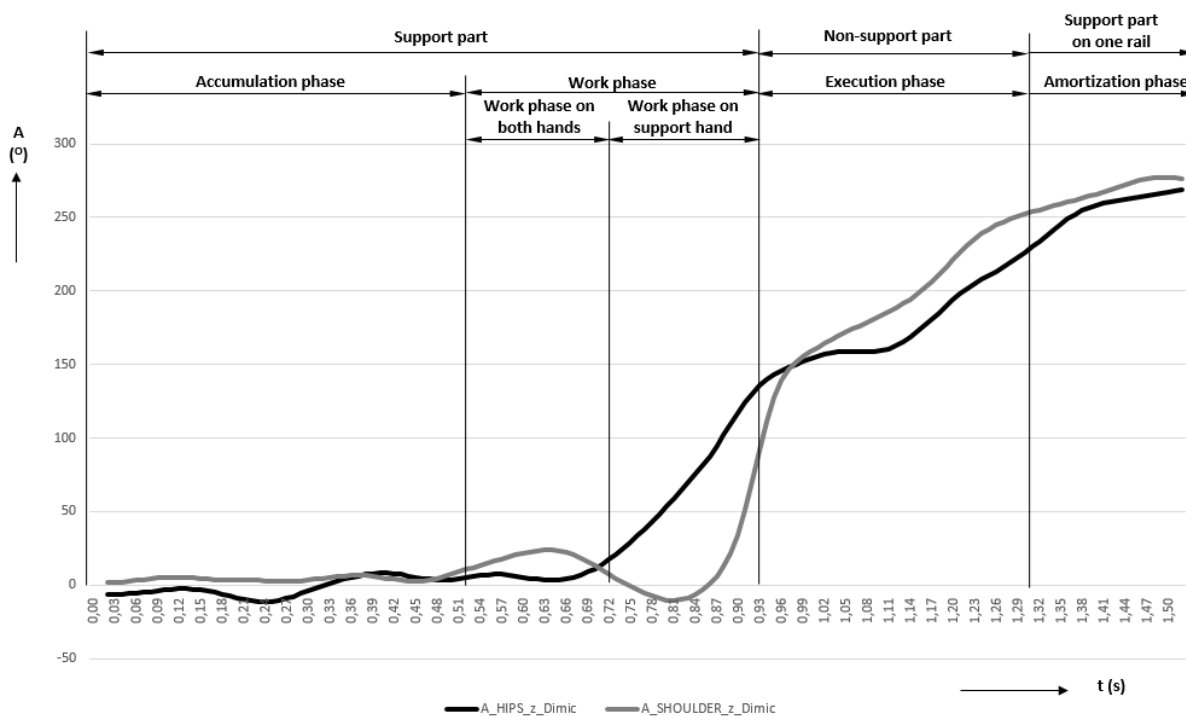

Figure 4. Rotation of shoulders and hips around the longitudinal axis.

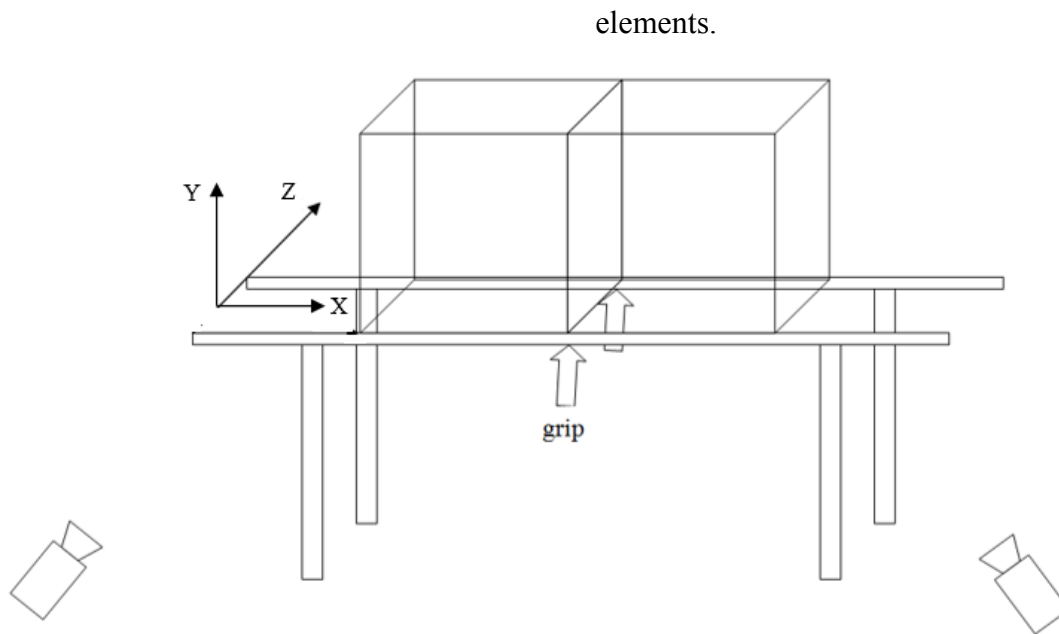

Figure 5. Space calibration.

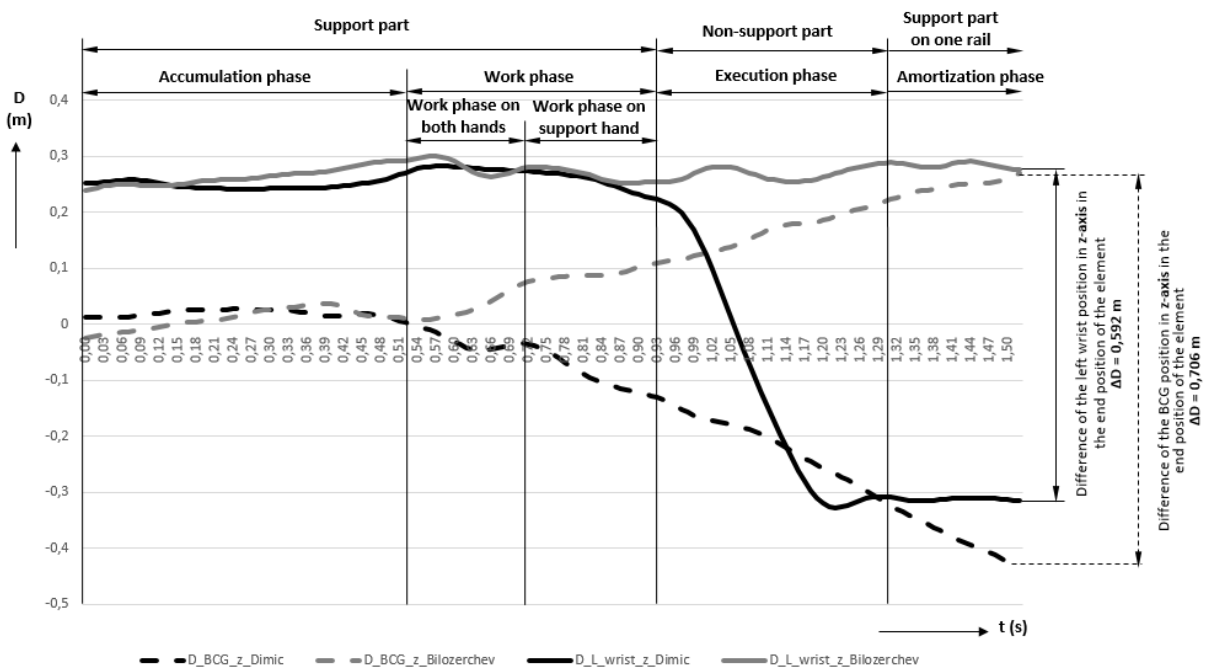

Figure 6. Comparison of paths of BCG and supporting arm (left wrist) during both

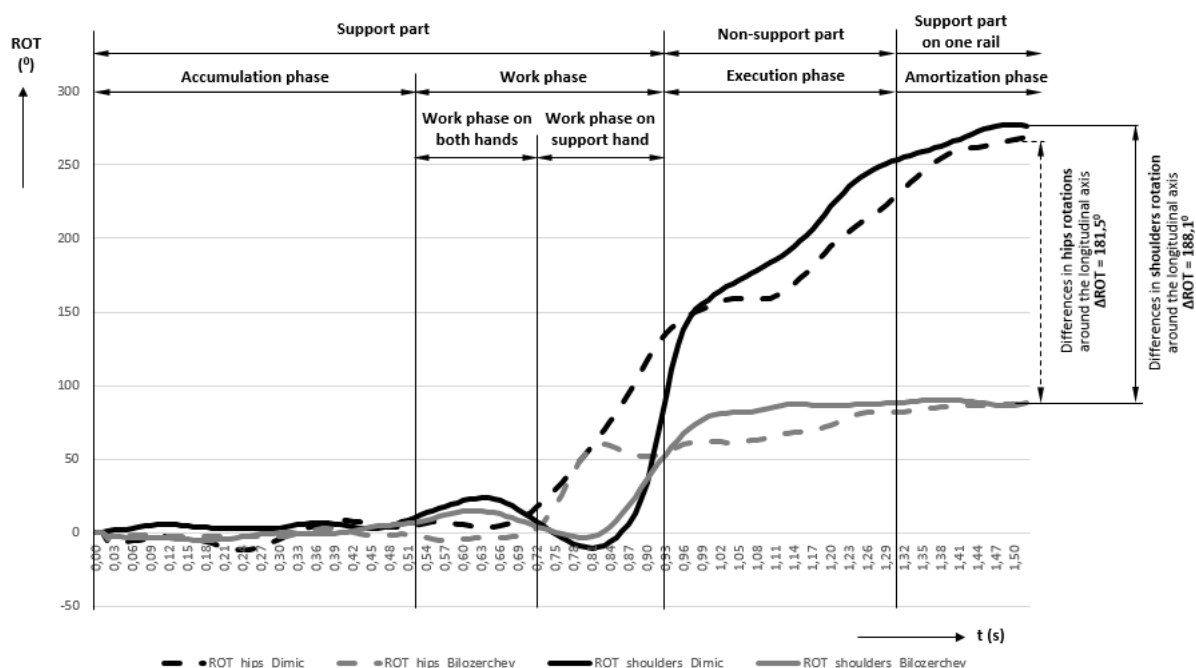

Figure 7. Comparison of hips and shoulders rotation around the longitudinal axis during both elements.

Table 1

Comparison of the evaluation of elements with similar movement structure and different quantity of turns around the vertical axis.

Element group (apparatus)	Element	Turns around vertical axis in (°)	Box Number (FIG, 2013)	Difficulty
Swing backward with turn (parallel bars)	Swing backward with ½ turn hop	180°	I.68	B
	Swing backward with ¾ turn hop to handstand	270°	I.69	C
	Swing backward with 1/1 turn hop to handstand	360°	I.70	D
Backward uprise to handstand (parallel bars)	Backward uprise to handstand	0°	II.26	B
	Backward uprise with ½ turn hop to handstand	180°	II.27	C
	Backward uprise with ¾ turn hop to handstand on 1 rail	270°	II.28	D
Flying giant swing backward with turns (high bar)	Flying giant swing backward with 1/1 turn	360°	I.45	C
	Giant swing backward with hop 3/2 turn	540°	I.63	C
Tkatchev (high bar)	Tkatchev stretched	0°	III.16	D
	Tkatchev stretched with ½ turn	180°	III.17	E
	Tkatchev stretched with 1/1 turn	360°	III.18	F

DISCUSSION

An analysis of kinematic parameters of movement in the element “Dimic” on parallel bars has revealed that the skill is performed in support on the bars and consists of the support and non-support parts. In the support part, when gymnast moves from handstand to the high forward swing, the activity of the gymnast aims to produce sufficient linear and angular velocity in order to execute desired movement in a non-support part. During the non-support part, gymnast moves the BCG and all other body parts approximately 0.7m away from the supporting arm (see Figure 6) and rotates the body around the longitudinal axis by approximately $\frac{1}{2}$ turn (see Figure 4). Combined with the rotation of body on a supporting arm in the support part of the skill, the total rotation equals to approximately $\frac{3}{4}$ turn (see Figure 7). Movement in the non-support part of the skill mainly depends on the efficient swinging in the support part of the skill (Kolar, Andlovic-Kolar & Štuhec, 2002; Manoni, et al., 1992a; 1992b). Movement in the non-support part of the skill represents a basis for the evaluation and classification of the skill by the experts according to the difficulty aspect and structural characteristics of the skill. The experts from the FIG MTC have matched the element “Dimic” in the Code of Points (FIG, 2013) with the “Bilozerchev” elements both from the aspect of difficulty and from the structural complexity of the movement. The authors of the study consider this act as incorrect, as the movement of the skills differs in both difficulty and structure, particularly in the non-support part of the elements.

A comparison of kinematic parameters of movement between the “Dimic” and “Bilozerchev” elements revealed important differences in the non-support part of the skills, which are crucial in both elements and determine their structural description, complexity and difficulty. Successful execution of “Dimic” skill requires from the

gymnast to perform larger movement of the BCG and other parts of the body in space (translation). Additionally, the gymnast needs to perform approximately $\frac{1}{2}$ turn more (rotation) than in the skill “Bilozerchev”. Findings indicate that these two skills have from the kinematic characteristics point of view *different motor structure* and that “Dimic” skill is **more complex** than “Bilozerchev” skill. Both kinematic characteristics of movement (path in meters and change of angle in degrees) are in both skills mostly performed in a non-support part (i.e., execution phase). According to the principles of conservation of linear and angular momentum, both quantities remain constant in a non-support part (as there are no external forces acting upon them). Consequently, it is evident that successful realisation of »Dimic« skill requires considerably larger amount of linear (translation of body) and angular momentum (rotation of body) in comparison to skill “Bilozerchev” (in the element “Dimic”, the displacement of BCG is larger by 0.181m or 70%, the displacement of supporting left arm is larger by 0.595m, the rotation of hips is larger by 181.5° or 207.2% and the rotation of shoulders is larger by 188.1° or 213.3%). It can be concluded that “Dimic” skill is **more difficult** than the “Bilozerchev” skill.

Findings in kinematic characteristics between the skills confirm the hypothesis that the initial classification of “Dimic” skill in the Code of Points (FIG, 2013, p. 116) seems incorrect and unjust to the gymnasts who can perform both skills and wish to include them in their competition routines. Classification also appears inconsistent with some other decisions about placing the skills into the Code of Points (FIG, 2013). Namely, skills with the execution part being performed mostly in the non-support part that increase in the amount of turns around the longitudinal axis, are characteristically awarded higher difficulty or/and structurally into different, independent boxes in the Code of Points (FIG, 2013). Some examples

of such classification are presented in Table 1.

CONCLUSION

Development of new skills in artistic gymnastics is a process linked to a technical knowledge of individual gymnast, theoretical knowledge of a close coaching team and the creativity of everyone involved in the process. A result of such process is a new gymnastics skill that has to be successfully performed in an official FIG competition in order to be evaluated through the decision of the FIG MTC. Evaluation process is an important part of the process as it determines the difficulty of the skill and its classification in the FIG Code of Points according to the structural characteristics of the skill. Evaluation process is carried out independently of the creators of the new gymnastics skill and entirely depends on the group of experts within the FIG TC, i.e., on their knowledge in the area of rational judgement of structural complexity of gymnastics skills.

The article used a method of biomechanical modelling and an analysis of kinematic characteristics of movement in order to present a new gymnastics element "Dimic" on parallel bars. According to the opinion of authors, the skill seems incorrectly classified by the FIG MTC in the Code of Points (FIG, 2013, p. 116). Namely, a comparison with skills that the FIG MTC members matched in both difficulty and structural complexity revealed that the "Dimic" skill is more complex from the aspect of kinematic characteristics and provision of linear and angular momentum than the skill "Bilozherchev". Furthermore, the study revealed that the classification of "Dimic" skill did not follow the guidelines for classification of other skills, which are similar in the type of movement, but differ one from another in the amount of rotation around the longitudinal axis in a non-support part of the skill. As a result, the authors suggest that the FIG MTC places the element "Dimic" in a separate box in

Code of Points and classify the skill as a D-value element.

Finally, the authors consider the classification of new skills and evaluation of their difficulty to be a complex process, which should not be left only to the subjective judgement of experts. The process should be primarily based on the use of methods that allow precise understanding of technical characteristics and motor structure in new skills. The article presents such method and its use.

REFERENCES

- Čuk, I. (1995). Kolman and Pegan saltos on high bar. In Jošt B. (Eds.), *Kinematična analiza gibanj v izbranih športnih panogah* [Kinematic analysis of movement in selected sport disciplines. In Slovenian.] (p. 195-198) Ljubljana: University of Ljubljana, Faculty of sport.
- Čuk, I. (1996). *Razvoj in analiza nove gimnastične prvine (seskok podmet salto naprej z bradlje)* [Development and analysis of the new gymnastic element (Cast to salto forward from the parallel bars). In Slovenian.]. Unpublished doctoral thesis, Ljubljana: Faculty of Sport, University of Ljubljana.
- Čuk, I., Atiković, A., & Tabaković, M. (2009). Tkachev salto on high bar. *Science of Gymnastics Journal*, 1(1), 5-15.
- Davis, J. (2005). Under somersaults on parallel bars. *Gym Craft*, 14, 6-7.
- Dempster, W.T. (1955). *Space Requirements of the Seated Operator*. WADC Technical Report 55-159, Ohio: Wright-Patterson Air Force Base.
- Gervais, P. & Dunn, J. (2003). The double back salto dismount from the parallel bars. *Sports Biomechanics*, 2, 85-101.
- Heng, T. (2007). Kinematical descriptors of circles on short pommel horse in men's artistic gymnastics. *Journal of Biomechanics*, 40, S741.
- Hiley, M. J., Wangler, R., & Predescu, G. (2009). Optimization of the Felge on Parallel Bars. *Sports Biomechanics*, 8(1), 39-51.

Fédération Internationale de Gymnastique - FIG (2013). *Code of Points for Men Artistic Gymnastics Competitions* (2013 Edition) Available at: [http://www.figgymnastics.com/publicdir/rules/files/mag/MAG%20CoP%202013-2016%20\(FRA%20ENG%20ESP\)%20July%202015.pdf](http://www.figgymnastics.com/publicdir/rules/files/mag/MAG%20CoP%202013-2016%20(FRA%20ENG%20ESP)%20July%202015.pdf). Accessed 23.03.2016.

Kolar, E., & Piletič, S. (2005). Dvojni stegnjeni salto z droga z obratom za 720°. [Double stretch somersault from high bar with turn for 720°. In Slovenian]. In Kolar, E., & Piletič, S. (Eds.) *Gimnastika za trenerje in pedagoge 1* [Gymnastics for coaches and teachers 1. In Slovenian] (p. 19-28). Ljubljana: Slovenian Gymnastics Federation.

Kolar, E., Andlovic-Kolar, K., & Štuhec, S. (2002). Comparative analysis of selected Biomechanics characteristics between a support backward swing and support swing for the 1¼ straddle-piked forward salto on the parallel bars. *Sports Biomechanics, 1* (1), 69-78.

Kolar, E., Samardžija Pavletič, M., & Veličković, S. (2015). Importance of biomechanical modelling for technical preparation of a gymnast. In: Samardžija Pavletič, M., & Bučar Pajek, M. (Eds.) *Scientific programme, plenary lectures, invited proceedings, book of abstracts and book of proceedings* (p. 9-30). Ljubljana: Slovenian Gymnastics Federation.

Kolar, E., Piletič, S., Kugovnik, O., Andlovic-Kolar, K., & Štuhec, S. (2005). Primerjava kinematičnih spremenljivk dobrih in slabih izvedb seskoka z bradlje. [A comparison of kinematic characteristics of good and bad executions of dismount from parallel bars. In Slovenian]. In Kolar, E., & Piletič, S. (Eds.) *Gimnastika za trenerje in pedagoge 1* [Gymnastics for coaches and teachers 1. In Slovenian] (p. 34-44). Ljubljana: Slovenian Gymnastics Federation.

Linge, S., Hallingstad, O., & Solberg, F. (2006). Modelling the parallel bars in Men's Artistic Gymnastics. *Human Movement Science, 25*(2), 221-237.

Manoni, A., De Leva, P., Carvelli, E., & Mallozzi, L. (1992a). Biomechanical analysis of a double backward salto at the parallel bars. In G. P. Brueggmann, & J. K. Ruhl (Eds.), *Proceedings of First International Conference Biomechanics in Gymnastics* (p. 475-485). Cologne: Bundesinstitute fur Sportwissenschaft.

Manoni, A., De Leva, P., Carvelli, E., & Mallozzi, L. (1992b). Comparative biomechanical analysis of three different forward saltos at the parallel bars. In G. P. Brueggmann, & J. K. Ruhl (Eds.), *Proceedings of First International Conference Biomechanics in Gymnastics* (p. 487-497). Cologne: Bundesinstitute fur Sportwissenschaft.

Marinšek, M., Kolar, E., Piletič, S., & Kugovnik, O. (2006). Kinematične značilnosti prvine diamidov na bradlji. [Kinematic characteristics of Diamidov on parallel bars. In Slovenian]. In Kolar, E., & Piletič, S. (Eds.) *Gimnastika za trenerje in pedagoge 2* [Gymnastics for coaches and teachers 2. In Slovenian] (p. 39-56). Ljubljana: Slovenian Gymnastics Federation.

Marinšek, M., & Kolar, E. (2007). A comparison of selected kinematical characteristics between successful attempts of elements Diamidov, Diamidov with 180° turn and Diamidov with 360° turn. *Kalokagathia, 47*, (3/4), 138-148.

Matveev, L.P. (1977). *Osnovi sportivnoj trenirovki*. [Basics of sports training. In Russian]. Moskva: Fiskultura i sport.

Opavsky, P. (1987). *Osnovi biomehanike*. [Basics of biomechanics. In Serbian]. Beograd: Naučna knjiga.

Prassas, S. (1994). Technique analysis of the back toss on the parallel bars performed by elite gymnasts. In Barabas, A., & Fabian, G. (Eds.) *Proceedings of the 12 International Symposium on Biomechanics in Sports* (p. 249-251). Budapest: Hungarian University for Physical Education.

Prassas, S. (1999). On Dismounts, Twists, Somersaults, etc., or Why it is Difficult to Do that Double Back Layout

Somersault? *International Journal of Sports Biomechanics* (6), 148-157.

Prassas, S., & Ariel, G. (2005). Kinematics of giant swings on the parallel bars. In Wang, Q. (Eds.) *Proceedings of the 23 International Society of Biomechanics in Sports*. Beijing: The China Institute of Sport Science, 951-953.

Prassas, S., Ostarello, J., & Inouye, C. (2004). Giant swings on the parallel bars: a case study. In Lamontagne, M., Gordon, D., Robertson, E., & Sveistrup, H. (Eds) *Proceedings of the 22 International Symposium on Biomechanics in Sports* (p. 345). Canada: University of Ottawa.

Smolevskij, V.G. (1992). *Lecture phase constitution of gymnastics, Structure of technical errors, Control and self-control*. Great Britain.

Tsuchiya, J., Murata, K., & Fukunaga, T. (2004). Kinetic analysis of backward giant swings on parallel bars. *International Journal of Sport and Health Science*, 2(1), 211-221.

Veličković, S. (2005). *Definisanje kinematičkog modela tehnike izvođenja najsloženijih gimnastičkih vežbi* [Defining a kinematic technical model of executing the most difficult gymnastics skills. In Serbian]. Unpublished Doctoral dissertation thesis. Novi Sad: Faculty of physical culture, University of Novi Sad.

Veličković, S., Kolar, E., Kugovnik, O., Petković, D., Petković, E., Bubanj, S., Bubanj, R., & Stanković, R. (2011). The kinematic model of basket to handstand on the parallel bars. *Facta Universitatis: Series Physical Education And Sport*, 9 (1), 55-68.

Veličković, S., Kolar, E., Kugovnik, O., Madić, D., Aleksić – Veljković, A., & Paunović, M. (2013). Prediction of the success of the basket to handstand on parallel bars based on kinematic parameters – a case study. *Facta Universitatis: Series Physical Education And Sport*, 11, (1), 9-21.

Yeadon, M.R. (1999). Learning how to twist fast. In Prassas, S., & Sanders, R. (Eds.) *Proceedings of the XVII International Symposium on Biomechanics in Sports* (p. 49-59). Perth: Edith Cowan University.

Corresponding author:

Edvard Kolar
University of Primorska
Science and Research Centre
Institute for Kinesiology
Garibaldijeva 1
6000 Koper
Slovenija
tel: +386 41 376 381
E-mail: edvard.kolar@olympic.si

SHORT HISTORICAL NOTES VIII

Anton Gajdoš, Bratislava, Slovakia

Ph.D. Anton Gajdoš born on 1.6.1940 in Dubriniči (today Ukraine) lives most of his life in Bratislava (ex TCH, nowadays SVK). He comes from gymnastics family (his brother Pavel have world championship medals) and he devoted his life to gymnastics. His last achievement is establishment of Narodna encyklopedia športu Slovenska (www.sportency.sk). Among his passion is collecting photos and signatures of gymnasts. As we tend to forget old champions and important gymnasts, judges and coaches, we decided to publish part of his archive under title Short historical notes. All information on these pages is from Anton's archives and collected through years.



JOSEF GÖHLER (November, 17 1911, Hosbach – January, 27 2001, Würzburg)



Dr. Josef Göhler was one of the most prominent gymnastics expert in the period from 1930 to 1982. His contribution to the gymnastics on his national (German) and international development have been in a many different ways e.g. an enthusiastic gymnast, as a writer, competitor, reporter and vice president of the German Gymnastics Federation from 1948 - 1982. He began the sport when he was 6 and trained at Hosbach. After a long career as a competitor, during which he was quite successful in the collegiate ranks, he turned his energies to reporting. His coverage of the 1936 Olympics marked the beginning of whole new passion for gymnastics

Dr. Göhler wrote many books and edited the fine magazine *Olympische Turnkunst* from 1966 - 1975. Very great work Dr. Göhler did in the world as expert-journalist, contributions to *Gymnast* magazine -USA its name at the time, now *International Gymnast* minimum 15 years from 1970. His books at beginning was for example: *Die romische Politik in Italien*, *Dissertation*, *Breslau*,

1938, Rom und Italien, 1939, 1974, Japanische Turnkunst, 1961 and some of the last was very important book - Geschichte der Turngeräte, Esslingen-Neckar, 1989.

Besides as an expert he served also as a city council member and as a pedagogue. His archives a huge treasure, which includes over 2300 of his articles, books and reports. As such important person, Jochen Henzel in 1997 made a dissertation about Jozef with title: "Being and becoming a German gymnast in the twentieth century.

Today Goehler's gymnastics archive is located in the Berlin Sportmuseum. Two of a large number of honours are: German Gymnastic Federation's- honorary membership and the merit-medal of the FIG presented to Dr. Josef Gohler at the WCh in Indianapolis in 1991 by President Juri Titov.



ALINA KABAYEVA (12 May 1983)



Alina is one of the most decorated rhythmic gymnasts with two medals from Olympic Games, 14 medals from World Championship and 21 from European Championship (out of them 18 gold – record of EC titles). Her long career started in 1998 with gold medal for all around at European Championship (at age of 15 years, she was the youngest European Champion) and stopped with gold medal with group at World Championship in 2007. She won all the possible titles at – Olympic Games, World Championship, European Championship, World Cup Final and Grand Prix Final. Her flexibility was something on the edge of possible, and she was also creative with her movements she was the first to perform (back split pivot with hand help, ring position with slow full turn, back scale pivot). After her gymnastics career, she moved into politics.

Photo by E. Langsley and with permission of International Gymnast Magazin

Medals

Competition

OG 2000	Bronze AA (all around)
OG 2004	Gold AA
WC 1999	4x Gold AA, Team, Ball, Ribon, 2x Silver Rope Hoop
WC 2001	Disqualified for using furosemide – medicine on black doping list
WC 2003	4x Gold AA, Team , Ball, Ribon, Silver Hoop, Bronze Clubs
WC 2007	1x Gold Team, Bronze Ribbon
EC 1998	Gold AA, Bronze Team
EC 1999	3x Gold AA, Team, Hoop, Silver Ribbon, Bronze Rope
EC 2000	5x Gold Team, Hoop, Ball, Zaragoza, Ribbon
EC 2001	4x Gold Team, Hoop, Ball, Clubs, Silver Rope
EC 2002	2x Gold AA, Team, Bronze Rope
EC 2003	Gold Team
EC 2004	2x Gold AA, Team
EC 2006	Silver AA
WCup 2000	3x Gold Rope, Ball, Ribbon, Silver Hoop
WCup 2004	2x Gold Hoop, Ribbon

COMPULSORY EXERCISES ON PARALLEL BARS AT OLYMPIC GAMES 1928

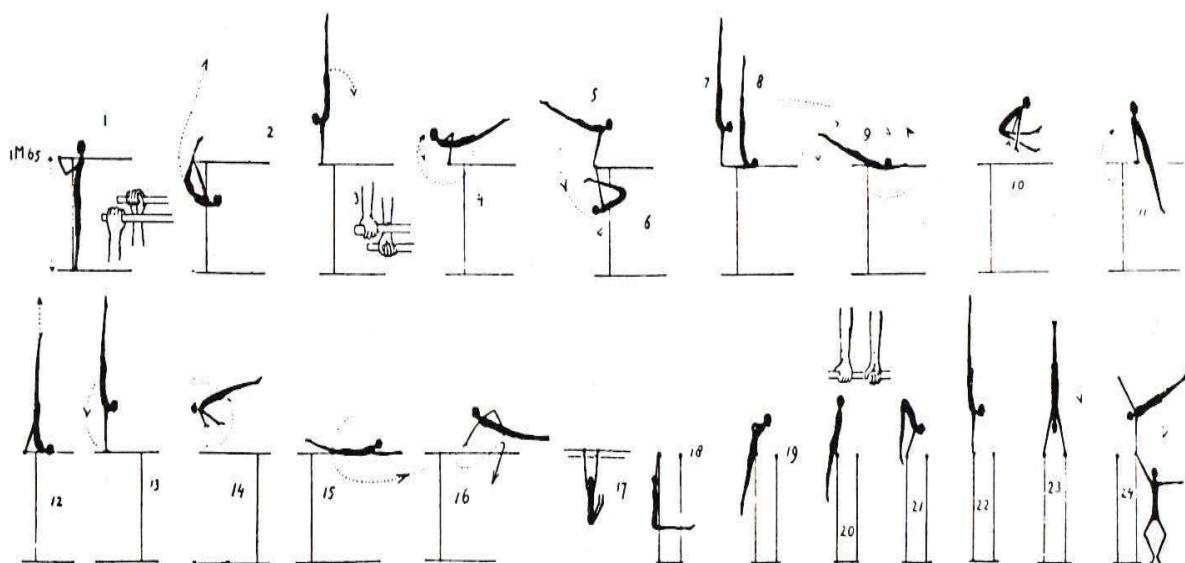

Picture say more than 1000 words.

Slovenski izvlečki / Slovene Abstracts

Andrzej Kochanowicz, Kazimierz Kochanowicz, Bartłomiej Niespodziński, Jan Mieszkowski, Piotr Sawicki

VPLIV NAČRTNE TELOVADBE NA NADZOR DRŽE TELESA PRI DEČKIH IN MLADINCIH

Namen raziskave je bil ugotoviti vpliv telovadbe otrok in mladostnikov na nadzor telesne drže z in brez uporabe vidnih informacij pri dinamičnih nalogah drže. V študijo je bilo vključenih 105 moških, od tega jih je 48 telovadilo in 57 jih ni. Obe skupini sta bili razdeljeni v tri skupine in sicer 8-10, 12-14 in 18-24 let. Nadzor drže telesa smo merili s pritiskovno dvo delno ploščo in sicer pri vzdrževanju položaja drže (z in brez vida) in dinamičnim spreminjanjem položaja z vidno povratno informacijo. Test ANOVA (skupina in starost) s ponovljenimi meritvami (vidna kontrola) je bil uporabljen za razlikovanje vpliva učinkov telovadbe v treh starostnih skupinah. Rezultati so pokazali, da je skupina telovadcev v vseh starostnih skupinah boljša pri vzdrževanju položaja drže ($p=0,013$) ne glede na uporabo vida, medtem ko ni bilo razlik med skupinami po starosti ($p=0.565$). Nadalje najmlajša skupina ima bistveno slabše rezultate kot drugi dve skupini. Pri dinamičnem vzdrževanju položaja z vidom so najslabše rezultate dosegli najmlajši netelovadci, ki so potrebovali največ časa za izpolnitev naloge. Rezultati so pokazali, da telovadba ima vpliv na izboljššan nadzor vzdrževanja položaja telesa, telovadeči niso povsem uspeli pokazati svojih zmožnosti pri posebnih neobičajnih držah in vidni povratni informaciji. Načrtno sodelovanje pri telovadbi v času šolske dobe poveča sposobnost za skladni nadzor položaja telesa.

Ključne besede: ravnotežje, vidna povratna informacija, propriorepcija, učinki vadbe.

Nafsika Karachle, Aspasia Dania, Fotini Venetsanou

VPLIV TELOVADBE NA GIBALNO USPEŠNOST PREDŠOLSKIH OTROK

Visoka stopnja gibalne spretnosti (GS) v zgodnjih letih je povezana z uspešnim delovanjem v vsakdanjem življenju in udeležbi v telesnih dejavnostih, tako v kratkoročnem in tudi dolgoročnem obdobju. Zato je naganje v programe gibanja, ki lahko povečajo GS predšolskih otrok je zelo pomembno. Cilj raziskave je bil raziskati vpliv 6-mesečne telovadbe na GS. 34 otrok iz Atenah, starih od 3-7 let ($4,7 \pm 1,2$ let) je sodelovalo v raziskavi, od tega 21 v poskusni skupini (ES pri telovadbi) in 13 pa je bilo dodeljenih v kontrolni skupini (KS) in ni sodelovala v nobeni organizirani obliki telesne aktivnosti. Pred in po telovadbi so bile opravljene v obeh skupinah meritve z Bruininks-Oseretsky preizkusom GS (Bruininks & Bruininks, 2005). ANOVA je pokazala, da čeprav sta obe skupini bistveno izboljšali svoje GS med dvema meritvama ($p < 0,001$), je ES znatno preseгла KS po telovadbi ($p < 0,05$). Glede na zgoraj navedeno je mogoče sklepati, da lahko s telovadbo učinkovito izboljšamo GS v zgodnjem otroštvu.

Ključne besede: meritve BOT-2, predšolski otroci gibalne spretnosti.

George C. Dallas, Costas G. Dallas, Evaggelos J. Simatos, Jeremy E. Simatos

PREHRAMBENA PRIPOROČILA IN SMERNICE ZA TELOVADKE: TRENUTNI VIDIKI IN NEGATIVNI VPLIVI

Predpubertetniki in pubertetniki, in zlasti telovadke (AG) in ritmičarke (RG), spadajo v skupino z visokim tveganjem za hudim pomanjkanjem osnovnih hranil, predvsem kalcija, železa, folne kisline, vitamina D in cinka. Povečane zahteve pospešenega pubertetnim razvoja v kombinaciji s potrebo po ohranitvi nižje telesne mase in intenzivna dnevna vadba (brez energetske predelave in ustreznega počitka), izpostavljajo predvsem za mlajše motnjam rasti, dolgoročne prehranske pomanjkljivosti, probleme čustvene narave (nizka samopodoba, nezadovoljstvo s telesno podobo, večkratno dnevno tehtanje, obsesije s telesno estetike in videza), hormonske motnje (amenoreja), prezgodnje utrujenosti, osteopenijo in še posebej povečano tveganje za poškodbe. Velika večina športnikov občutek, da so na stalni (kronične) omejitvi prehrane. To je značilno za športnike, da preživijo ure vsakodnevnega treninga le s pitjem vode in brez prigrizkov in vaditelji se tega zavedajo. Odkrivanje in diagnostično ocenjevanje prehranske pomanjkljivosti / vrzeli in prihodnjih prehranskih odvisnosti, motnje v razvoju je področje študija za vse kvalificirane športne dietetike. S to mislijo, je namen tega pregleda zagotoviti usmerjeno prehransko podporo za pot do vrhunskih športnikov AG in RG s ciljem in poudarkom na krepitvi imunskega sistema, prehransko strategijo za direktno izrabo energije in nadzor pravočasno dnevnega vnosa hrane med letnimi vadbenimi obdobji.

Ključne besede: telovadba, ritmika, slaba prehrana, navodila, ženska triada.

Joca Zurc

BILO JE VREDNO – PONOVILO BI TO!: POGLEDI NA ŽIVLJENJE VRHUNSKIH TELOVADK

Olimpijsko gibanje poudarja pomen varovanja zdravja športnikov in odpravo vseh morebitnih tveganj. Številni mednarodni dokumenti imajo podobna priporočila, zlasti Konvencija Združenih narodov o otrokovih pravicah. Vendar vrhunski šport še vedno predstavljajo tveganje, še posebej pri športnikih, ki tekmujejo že kot odraščajoči otroki. Ženske orodna telovadba je olimpijski šport, kjer je starost tekmovalcev bila najnižja v zadnjih 40 letih. Namen naše empirične raziskave je bil ugotoviti mnenja telovadk na njihove športne kariere in vrhunske dosežke v telovadbi. Poleg tega nas je zanimalo mnenje vaditeljev glede ustrezne starosti za otroka, da začne z vadbo in tekmovanji pri ženski orodni telovadbi. Rezultati kvalitativne raziskave, opravljene na vzorcu 26 dejavnih in 11 upokojenih slovenskih telovadk in štirimi vaditelji je pokazala, da bi anketiranci ponovili kariero, kljub posebnemu načinu življenja, marsikateri žrtvi, nezaželenimi učinki, s katerimi se soočajo, in posledicami za njihovo telesno in duševno zdravje. Vaditelji so se strinjali, da je starost otroka določa njihovo telovadno kariero, vendar se njihova mnenja razlikujejo glede tega, ali naj se starostna meja za vstop v članska tekmovanja dvigne s 16 let na 18 let. Študija vsebuje tudi priporočila za bolj uspešen pristop k delu z mladimi, nadarjenimi športniki.

Ključne besede: otrok vrhunski športnik, telovadba, ženske, etika, človekove pravice, kvalitativna analiza.

Igor Pušnik, Ivan Čuk, Vedran Hadžič

VPLIV NOVEGA MODELA OBROČEV NA KROGIH NA TEMPERATURO DLANI

Obroči na krogih imajo že zelo staro obliko, ki je stara že več kot 100 let. Naredili smo dve novi obliki obročev – 1. z ravnim delom za prijem in 2. z anatomskim oblikovanim delom za prijem. Uspešnost novih modelov smo primerjali s klasičnimi pri izvedbi gugov v vesi. Vsi obroči so bili istega premera in materiala, medtem ko je bila svetlobna razdalja med zgornjim in spodnjim premerom obroča enaka. Izmerili smo osemnajst oseb. Spremenljivke so bile telesna višina, telesna teža, indeks telesne mase, širina dlani in dolžina dlani, moč stiska pesti in temperaturo kože na dlani pred in po izvedbi gugov. Rezultati kažejo, da se temperatura kože niža in ta padec temperature je najbolj izrazit pri klasičnih in ravnih obročih. Spremembe temperature kože niso povezane z indeksom telesne mase, relativne moči prijema, širina dlani in dolžine dlani in zdi se, da se razlogi za nižjo temperature kože lahko povežeta s položajem dlani nad srcem in oblike obročev. V smislu ohranjanja dobrega kinestetičnega zaznavanja prijema, vsaj za šolsko in rekreativno uporabo, se zdi, da je boljša izbira od klasičnih obročev ali obročev z ravnim delom, prijemu anatomsko oblikovani obroči.

Ključne besede: telovadba, termografija, dlan, prijem.

George C. Dallas, Paschalis Kirialanis, Costas G. Dallas, Vassilis Mellos

UČINKI VADBE NAJVEČJE IZOMETRIČNE SILE PRI MLADIH TELOVADCIH

Različne metode so bile razvite za ocenjevanje mišične moči različnih udov. Namen te raziskave je bil preučiti maksimalno prostovoljno izometrično moč 57 mladih telovadcev in 74 netelovadcev. Ti so bili merjeni s testi izometrične sile upogibanja in iztegovanja v sklepih zgornjih in spodnjih okončin med 5-sekund trajajočo največjo prostovoljno izometrično silo na levi in desni strani. Rezultati so pokazali pomembne razlike med telovadci in netelovadci ($p < 0,05$); poleg tega so pokazali: a) višje vrednosti na desni z upognjenim komolcem in ramenskem sklepu; b) višje vrednosti na levi z upognjenim komolcem, ramenu in kolku, c) višje vrednosti pri iztegu na desni strani za komolec, rame, kolk in koleno, d) višje vrednosti pri iztegu na levi strani za komolec, ramo in kolk. Zgornje rezultate je treba sprejeti v skladu z obravnavo vaditeljev, ki želijo izboljšati moč in splošno raven usposabljanja svojih športnikov.

Ključne besede: mišična sila, izometrično krčenje, telovadba.

Edvard Kolar, Sebastijan Piletić, Klemen Bedenik, Mitja Samardžija Pavletić, Stanko Štuhec, Saša Veličković

KINEMATIČNA ANALIZA NOVE PRVINE »DIMIC« NA BRADLJI IN PRIMERJAVA S PRVINO »BILOZERČEV«

Razvoj in priznavanje novih prvin je predmet ocenjevanja moške tehnične komisije FIG glede na zahtevnost prvine. Pri tem člani komisije upoštevajo predvsem svoje znanje in tudi subjektivne občutke o težavnosti prvine. Za razvoj prvine »Dimic« je bila uporabljena metoda biomehanske modeliranja. Člani tehnične komisije so prvino »Dimic« ocenili z enako težavnostjo kot prvino "Bilozerčev". Narejena je bila 3D kinematična analiza obeh prvin, ki jih je izvedel isti telovadec. Kinematična analiza je bila narejena z APAS sistemom, telo je predstavljal model s 17 točkami in 15 segmentov. Primerjava kinematičnih značilnosti (gibanje telesa težišča in opora z levo roko, količino vrtenja okoli vzdolžne osi) je pokazala velike razlike v brezopornem delu tako v strukturnih značilnosti in zahtevnosti izvedbe od telovadčevih spretnosti. Glede na rezultate je mogoče sklepati, da je ocena težavnosti prvine »Dimic« napačna v primerjavi s prvino »Bilozerčev« in bi morala biti ocenjena kot težja prvina.

Ključne besede: nova prvina, vrednotenje, težavnost, Pravila za ocenjevanje

REVIEWERS 2016

DEAR FRIENDS, THANK YOU FOR YOUR DILIGENT WORK.

George Dallas

Boštjan Jakše

Jernej Pajek

Juraj Kremenicky

Roman Farana

William Sands

Ignacio Rodriques Grande

José Fereirinha

Mateja Videmšek

Miha Marinšek

Vedran Hadžič

Bessem Mkaouer

Christoph Schärer

Michele Carbinato

Juan Leon-Prados

Muhamed Tabaković

Kamenka Živčić Marković

Maja Bučar Pajek

Eunice Lebre

Marco Bortoleto

Cesar Peixoto

Ruben Goebel

Stefan Brehmer

Lauritia Schiavon

Sunčica Delaš

Matej Majerič

Marjeta Kovač

Carlos Araújo

Olivia Donti

Hardy Fink

Spiros Prassas

Aurore Huchez

Benjamin Bango

Helmut Geiblinger

Michel Marina

Nejc Šarabon

Miriam Nonomura

Marta Bobo

Catarina Leandro

Keith Russell

Ivan Čuk
Editor-in-Chief

**Kamenka Živčić Marković
Tomislav Krističević**



OSNOVE SPORTSKE GIMNASTIKE



ZAGREB, 2016.

Nakladnik: Kineziološki fakultet Sveučilišta u Zagrebu

Za nakladnika: prof. dr. sc. Damir Knjaz

Recenzenti:

prof. dr. sc. Muhamed Tabaković, Fakultet sporta i tjelesnog odgoja, Univerzitet u Sarajevu

doc. dr. sc. Maja Horvatin Fučkar, Kineziološki fakultet Sveučilišta u Zagrebu

doc. dr. sc. Miljan Grbović, Fakultet sporta i fizičkog vaspitanja, Univerzitet u Beogradu

Urednica: prof. dr. sc. Kamenka Živčić Marković

Lektura i korektura: Vesna Muhoberac

Grafičko oblikovanje i prijelom: Branko Hrvoj

Odlukom Senata Sveučilišta u Zagrebu na sjednici održanoj 9. veljače 2016. (Klasa: 032-01/15-01/51, Urbroj: 380-061/252-16-5) odobrava se korištenje naziva sveučilišni udžbenik – *Manualia Universitatis studiorum Zagrebiensis*

Tiskano uz potporu Ministarstva znanosti, obrazovanja i sporta.

ISBN 978-953-317-041-1

CIP zapis je dostupan u računalnome katalogu Nacionalne i sveučilišne knjižnice u Zagrebu pod brojem 000937487.

© Sva prava pridržana.

Svoj doprinos u izradi udžbenika dale su osobe koje su demonstrirale vježbe (abecednim redom): Aida Badić, Filip Boroša, Marija Fišter, Antonija Golubić, Ivana Gorišek, Ana Marija Kovačić, Lucija Milčić, Saša Šolja. Crteže izradila Martina Sakač, a materijal za izradu kinograma snimile su: Tea Lagančić, Marta Janković i Josipa Jerčić.

Kamenka Živčić Marković and Tomislav Krističević, both professors at the Faculty of Kinesiology, University of Zagreb, have published university textbook *Fundamentals of artistic gymnastics*. It is the first comprehensive textbook in the field of artistic gymnastics written in Croatian, and is published by Zagreb Faculty of Kinesiology. Students entering advanced studies of artistic gymnastics may have difficulties in overcoming comprehensive and elaborated terminology and this book provides easy to understand key concepts and current debates in the field.

The book consists of four main parts; the first part discusses the theoretical basis of artistic gymnastics and gives insight in its development and the role and importance in teaching physical education. The second part of the book is the most comprehensive part focusing on description of artistic gymnastics disciplines, equipment and techniques. The text is based on previous scientific researches, theoretical knowledge and practical experience and supported by great number of expert and especially scientific references. Rules and regulations are described in third part while the fourth part consists of two addendums: current gymnastics lessons in primary schools and alphabetical index.

Table of Contents:

Foreword; Chapter 1: Fundamentals of artistic gymnastics; Definition and disciplines, Gymnastics terminology, Role and importance of artistic gymnastics in schools, Teaching methods of artistic gymnastics; Chapter 2: Techniques and teaching methods of basic gymnastics elements; Basics of acrobatic elements, Preparatory exercises for acrobatic elements, Technique and teaching methods of acrobatic elements, Basics of vaulting, Preparatory exercises for vaulting, Techniques and teaching methods for different phases of vaulting, Techniques and teaching methods in basic school vaulting, Basic preparatory motions on trampoline, Basics of exercising supports and hanging, Basics of exercising on uneven bars and high bar, Preparatory exercise for elements on uneven bars and high bar, Techniques and teaching methods of basic gymnastics elements on uneven bars and high bar, Basics of exercising on rings, Techniques and teaching methods of basic gymnastics elements on rings, Basics of exercising on parallel bars, Techniques and teaching methods of basic gymnastics elements on parallel bars, Basics of exercising on pommel horse, Techniques and teaching methods of basic gymnastics elements on pommel horse, Basics of exercising on balance beam, Techniques and teaching methods of basic gymnastics elements on balance beam, Chapter 3: Rules and regulations; Development of Code of points, Code of points for women's gymnastics, Code of points for men's gymnastics, Basics of judging in Croatia; Chapter 4: Current gymnastics lessons in primary schools; alphabetical index. References.